

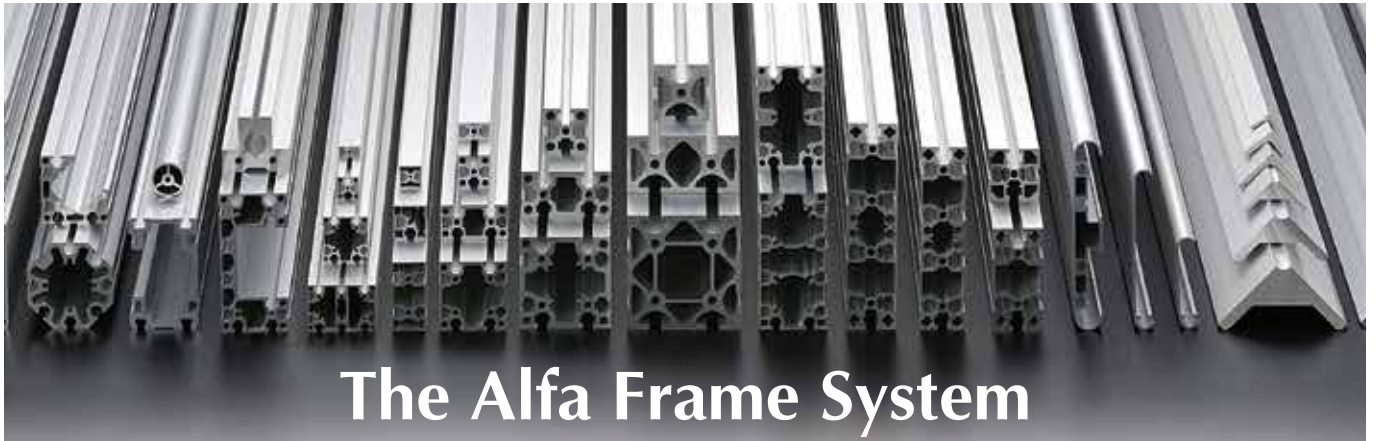

Alfa Frame System Product Guide

2018-2019



The Alfa Frame System

ความเป็นไปได้ไม่มีสิ้นสุดด้วยระบบอลูมิเนียมโพรไฟล์
Possibilities are infinite with Aluminun Profile System

ระบบอัลฟา (Alfa System) ประกอบด้วยชุดอลูมิเนียมเฟรม โดยเชื่อมชิ้นส่วนด้วยอุปกรณ์ยึดติดและส่วนประกอบซึ่งออกแบบเฉพาะเพื่อให้รวดเร็วและง่ายต่อการผสมผสานและประกอบโครงสร้างที่กันคลุมเครื่องจักรที่กันคลุมและเสากันเพื่อความปลอดภัยได้อย่างแข็งแรงและทนทานเพื่อที่จะลดต้นทุนการออกแบบและลดระยะเวลาประกอบได้อย่างมีนัยสำคัญเราจึงเตรียมระบบเพื่อสนับสนุนการออกแบบอัตโนมัติอย่างพิเศษและอลูมิเนียมเฟรมซึ่งพิมพ์ข้อมูลที่เป็นไปตามรายการสินค้าและแบบประกอบ

The Alfa System consists of a family of aluminum profiles, connecting brackets and accessories designed and specified to facilitate Fast and Easy Integration and Assembly into strong and rigid structures for Machine Cover, Safety Cover & Fence, and various kinds of main frame. To make significant reduction of your design and assembly time, we provide our special automatic design support system and original Marking Frame with printed necessary information on parts list and assembly drawings.

ALFA FRAME SYSTEM ตัวอย่างที่แนะนำ Introduction Example



Machine Cover

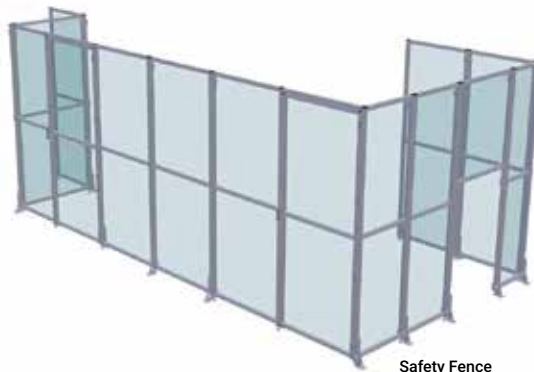

Safety Fence



Fence



Wagon



Wagon



Desk



Partition



Shelf



Toolbox



Safety Cover



Footstool

ระบบการออกแบบอัตโนมัติพิเศษสำหรับอลูมิเนียมเฟรม **KAKCHAR™** Special Automatic Design System for Aluminium Profile

เราขอเสนอบริการงานอลูมิเนียมเฟรมที่เหมาะสมกับลูกค้า We offer Solution of Aluminium Profile to be fit to customers

เรายินดีที่จะสนับสนุนด้านวิศวกรรมเครื่องจักรเพื่อประหยัดแรงงานด้วยการลดระยะเวลาและภาระงาน ทั้งยังสามารถพัฒนาคุณภาพการในการประกอบคุณจะได้รับวิธี Outsource ที่ยอดเยี่ยมในการออกแบบเพื่อการประกอบและติดตั้ง

We are pleased to support your machinery engineering for manpower saving to reduce working time & load, and also improvement of assembly quality. You have our excellent outsourcing way from design to assembly and installation.

1

แจ้งความต้องการ Request

จัดทำแบบที่ต้องการของคุณโดยระบุขนาดและรูปทรง แล้วส่งคำสั่งพร้อมแบบที่ต้องการโดยแฟกซ์
Make your request drawings to specify dimensions and figures.

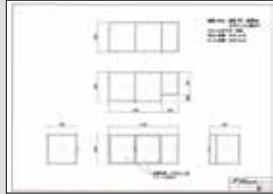

(ตัวอย่าง) แบบที่ลูกค้าต้องการ
Your request drawing (sample)

2

สนับสนุนการออกแบบ Design Support

ให้การออกแบบอัตโนมัติเพื่อเพิ่มประสิทธิภาพ เราจัดเตรียมบริการที่รวดเร็วเพื่อการเขียนแบบทุกประเภท

Utilize our automatic design to boost your efficiency. We provide speedy service for all types of drawing.

เราสามารถจัดทำ
แบบ 3D, แบบ 2D,
3D-PDF, DXF, STEP
แบบสำหรับการประกอบ
แบบสำหรับตำแหน่งน็อต

We can supply
3D drawing, 2D drawing
3D-PDF, DXF, STEP
Assemble drawing
Nut position drawing



3D drawing and parts list



2D drawing

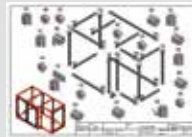

Assemble Drawing



Nut layout Drawing



3D PDF

3

การประกอบ & การส่งมอบ Assembly & Delivery

เลือกวิธีการจัดส่งได้ จะเลือกเป็นชิ้นส่วนเพื่อประกอบเองตามความต้องการก็ได้

Choose delivery methods from pieces only to assemblies according to your request.

ประกอบโดยลูกค้า Assembly by customer (NIC จัดส่งส่วนประกอบ) (NIC dispatches components)



ส่วนประกอบ + แบบสำหรับการประกอบ
Components + Assembly drawing



ส่วนประกอบ (ที่ mark แล้ว) + แบบสำหรับการประกอบ
Components (marked) + Assembly drawing



ส่วนประกอบ (ที่ Mark แล้ว) + อลูมิเนียมเฟรมพร้อมน็อต + แบบสำหรับการประกอบ
Components (Marked) + Aluminum frame with the nut + Assembly drawing

ประกอบโดย NIC Assembly by NIC (ลูกค้าต้องการให้ประกอบ) (customer requests assembly)



สินค้าที่ประกอบเรียบร้อยแล้ว
Complete assembled item



ประกอบที่หน้างานของลูกค้า
On-site installation

Marking System™

เพื่อลดระยะเวลาการประกอบได้อย่างมีนัยสำคัญ และคุณไม่สามารถพบระบบใดในโลกยกเว้นระบบ Marking Frame ของเราที่พิมพ์ข้อมูลรายละเอียดชิ้นงานและแบบในการประกอบ

ใช้บริการของเรา "เฟรมพร้อมส่วนประกอบยึดติด" เพื่อลดต้นทุนให้คุณอย่างมีประสิทธิภาพสูงสุด

To make significant reduction of assembly time, you could not find any system in the world except our Marking Frame with printed necessary information on parts list and assembly drawings. Please utilize our service of "Frame with inserted nuts" for your further cost reduction.

ผลที่ได้ Effect image

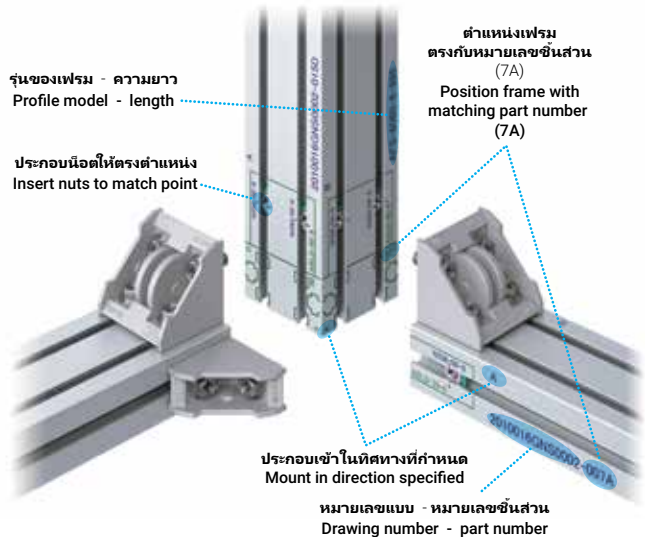
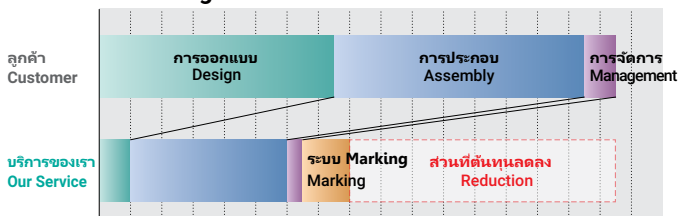

Advantage

วัสดุเหล็กแบบดั้งเดิม ต้องใช้ 6 ขั้นตอน
Traditional Steel Materials are a 6-STEP Process

ออกแบบ
Design

ตัด
Cutting

เชื่อม
Welding

เข้าเครื่อง
Machining

ทาสี
Painting

ประกอบ
Assembly

ระบบอัลฟาเฟรม (Alfa Frame System) มี 3 ขั้นตอน
The Alfa Frame System is a 3-STEP Process

ออกแบบ
Design

ตัด
Cutting

ประกอบ
Assembly

Basic Alfa Frame

เป็นเฟรม มาตรฐาน ในระบบ Alfa Frame โดย Basic Frame นี้ถูกออกแบบให้เหมาะสมกับ งานในรูปแบบ โครงสร้างทุกประเภท เพื่อให้ง่ายต่อการประกอบ โครงสร้าง เพียงแค่ใช้ Bolts, Brackets, และ Accessories อื่นๆ ในระบบอลูมิเนียมเฟรมก็สามารถผลิตสินค้าให้คุณได้

These are the basic frames that build the foundation of the Alfa Frame System. This basic frame is designed to suit exterior shapes and T-slots for assembly. By using bolts, brackets and other accessories, the Aluminum Profile system can be custom built for you.

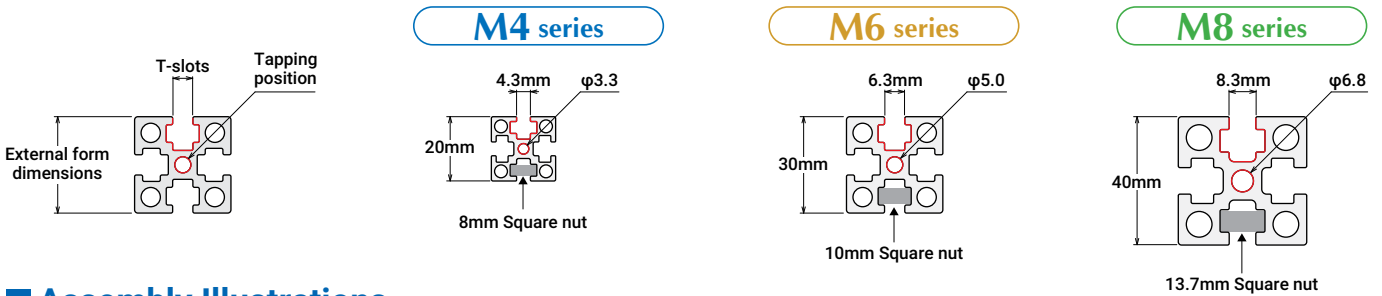

Assembly Illustrations

อย่างง่ายตายเพียงต่อเฟรมด้วย brackets หรือ bolts โดยไม่มีขั้นตอนดั้งเดิมเช่นการเชื่อม
คุณอาจจะเลือกวิธีการประกอบเช่น ประกอบด้วย [Bracket connection] หรือ [Spot facing connection].

It is easy that the connecting frames are done by only brackets or bolts without particular processes such as welding. You may choose some options as connecting methods such as [Bracket connection] or [Spot facing connection].

<p>Bracket connection</p> <p>วิธีการต่อแบบพื้นฐานสามารถเลือกโดยดูจาก ความแข็งแรงที่จำเป็น</p> <p>Basic connection method can be chosen to necessary strength.</p>	<p>Flat Bracket connection</p> <p>เหมาะสำหรับฉากและการเสริมความแข็งแรง</p> <p>Good to squareness and reinforcement.</p>	<p>Corner Bracket connection</p> <p>ง่ายสำหรับการเชื่อมต่อสองและสามทิศทาง</p> <p>Easy for connections of three and two directions.</p>	<p>V Bracket connection</p> <p>เหมาะสำหรับการเสริมความแข็งแรงของมุมและการเชื่อมต่อ</p> <p>Suitable for angle reinforcement and connection.</p>
<p>End Connector connection</p> <p>เหมาะในกรณีที่ จะเชื่อมต่อกับ panel โดยไม่มี bracketing.</p> <p>Suitable in case of panel mounting and not bracketing.</p>	<p>Joint Bracket connection</p> <p>ใช้ในกรณีที่ จะเชื่อมต่อกับเฟรม</p> <p>Can be used in case of connecting frames.</p>	<p>Steel Bracket connection</p> <p>อาจจะใช้ลดต้นทุนในการใช้ Steel bracket</p> <p>Possible to cut cost as using steel bracket.</p>	<p>Additional Spot facing/Tapping</p> <p>เหมาะสำหรับ fitting door</p> <p>Good connecting method in case of fitting doors.</p>

■ Factory Automation

NIC Autotec พัฒนา FA Equipment ให้ตรงความต้องการที่หลากหลาย ผลงานที่ผ่านมาของเราจากที่หนึ่งสูงอีกที่หนึ่ง จากให้ตรงกับความต้องการของโรงงานผลิตเครื่องจักร สุขุมิคอนดักเตอร์ และโรงงานส่วนประกอบอิเล็กทรอนิกส์ซึ่งต้องการสภาพแวดล้อมที่สะอาดเป็นพิเศษ โรงงานยาและอาหารซึ่งต้องการสุขอนามัยมาเป็นอันดับสูงสุด เรามีความสามารถและพร้อมที่จะท้าทายกับสถานที่สถานการณ์ใหม่

Development of FA Equipment by NIC Autotec satisfies a broad range of needs. Our respectable track record range from place to place, from meeting the needs of machine processing plants, to semiconductor and electronic components plants which require ultra-clean environments, and even pharmaceuticals and food factories where hygiene is the top priority. We are able and ready to face challenges by facing new on-site situations.

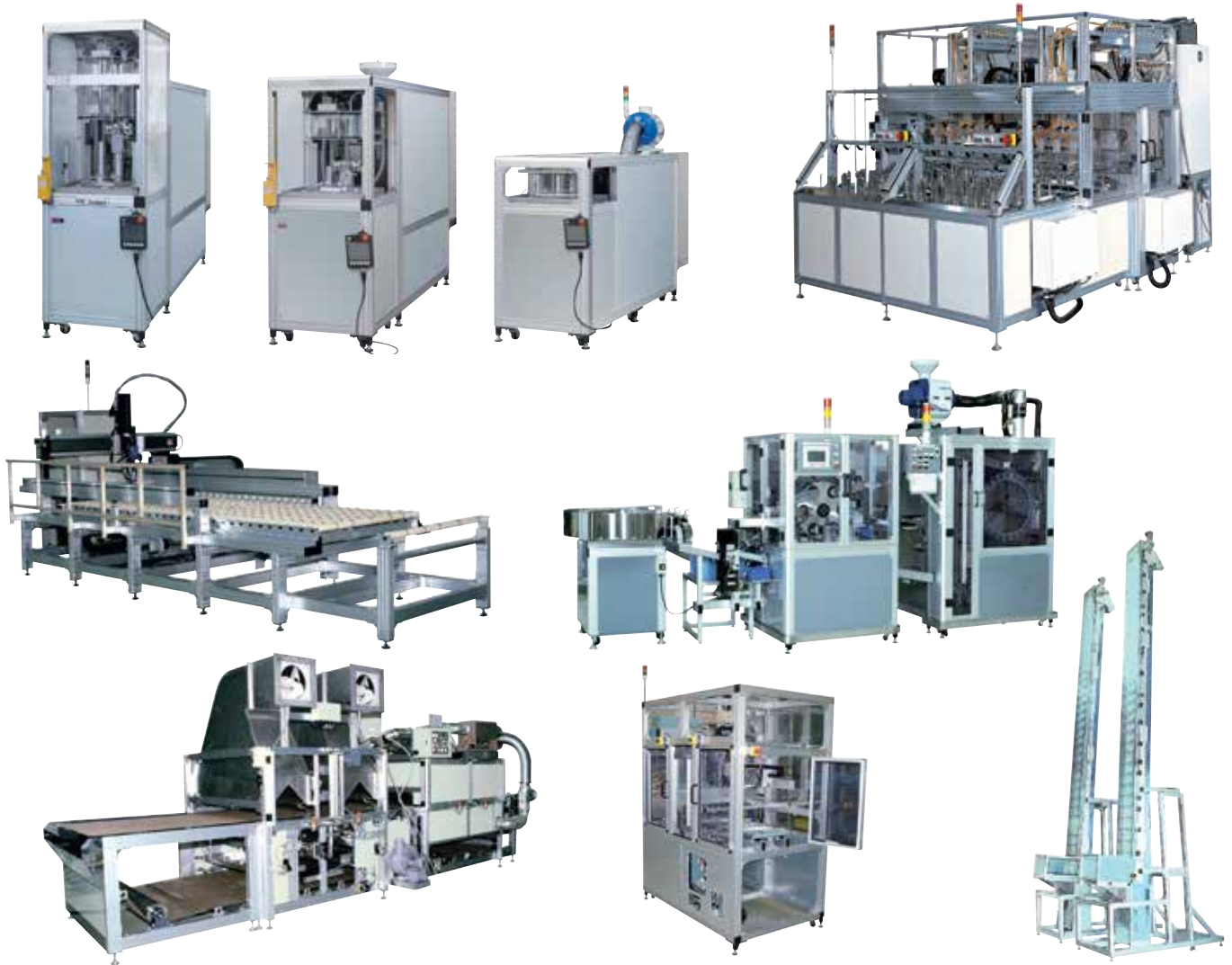

■ Cleanroom Products (Alfa Clean System)





เรายินดีที่จะนำเสนอสินค้าที่มีคุณภาพ เพื่อให้เหมาะสมกับความต้องการของลูกค้า จะทำให้คุณสามารถปรับเปลี่ยนชิ้นงานตามรูปแบบได้ง่ายขึ้น นี่คือเหตุผลที่ทำให้เราจึงเลือกใช้อลูมิเนียม ในระบบ Alfa Frame เพื่อให้ได้สินค้าที่มีคุณภาพสูงหับลูกค้าของเรา

There are reasons why we chose Aluminum frame configuration Alfa Frame System as high quality product for our customers. We are happy to offer you a lightweight, quick solution to meet various requirements, including assembly, disassembly and even layout alterations.













Clean Booth / Environmentally / Clean Desk / Clean Bench





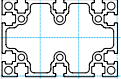
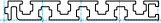

M4 Basic Frame

				
20mm				
				
	AFS-2020-4 page 8	AFS-2040-4 page 8	AFS-2060-4 page 8	AFS-4040-4 page 8



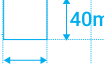

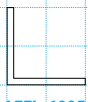
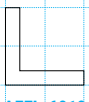





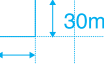









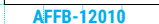







M6 Basic Frame

						
30mm						
						
	AFS-3030-6 page 9	AFS-3030L-6(-YE) page 9	AFS-3030F-6 page 9	AFS-3060-6 page 9	AFS-3060L-6 page 10	AFS-3060F-6 page 10
						
	AFS-3090-6 page 10	AFS-30120-6 page 10		AFS-6060-6 page 11	AFS-6060L-6 page 11	AFS-6060F-6 page 11
						
	AFS-6090B-6 page 11	AFS-30120-6 page 10				

SP Special Frame

						
30mm					40mm	
						
	AFEL-3005 page 18	AFEL-3010 page 18	AFEL-6005 page 18	AFEL-6010 page 18	AFEL-4005 page 18	AFEL-8005 page 18

SP Special Frame

						
30mm					40mm	
						
	AFFB-03005 page 19	AFFB-06005 page 19	AFFB-09005 page 19	AFFB-12005 page 19	AFFB-04005 page 19	AFFB-08005 page 19
						
	AFFB-03010 page 19	AFFB-06010 page 19	AFFB-09010 page 19	AFFB-12010 page 19	AFFB-04010 page 19	AFFB-08010 page 19
						
		AFFB-06012 page 19	AFFB-09012 page 19			
						
	AFFB-03015 page 19	AFFB-06015 page 19	AFFB-09015 page 19	AFFB-12015 page 19		AFFB-08015 page 19
						
	AFFB-03020 page 19	AFFB-06020 page 19	AFFB-09020 page 19		AFFB-04020 page 19	AFFB-08020 page 19
						
	AFFB-03030 page 19	AFFB-06030 page 19			AFFB-04040 page 19	AFFB-08040 page 19

M8

Basic Frame

40mm

40mm

AFS-4040-8 page 13

AFS-4040L-8(-YE) page 13

AFS-4040-8 page 13

AFS-4080-8 page 13

AFS-4080L-8(-YE) page 14

AFS-4080-8 page 14

AFS-40120-8 page 14

AFS-8080-8 page 14

AFS-8080L-8 page 15

AFS-8080-8 page 15

AFS-80160-8 page 15

45mm

45mm

AFS-4545L-8 page 15

AFS-4590B-8 page 16

AFS-9090L-8 page 16

AFS-90180L-8 page 16

50mm

50mm

AFS-5050-8 page 16

AFS-50100-8 page 17

AFS-100100C-8 page 17

SP

Special Frame

45mm

45mm

50mm

50mm

AFFB-04505 page 19

AFFB-04512 page 19

AFFB-10015 page 19

AFFB-20015 page 19

AFFB-10020 page 19

AFFB-20020 page 19

AFFB-25015 page 19

AFFB-25020 page 19

BKF

Bracket Frame

30mm

30mm

AFL-3030 page 18

Aluminium Frame M4 M6 series

Aluminium Frame

Bracket

Accessory

Bolts & Nuts

Rail Frame

Appendix

M4



Model Number
AFS-2020-4

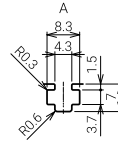
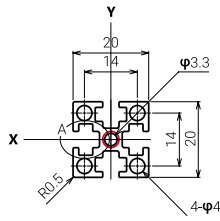

○ ตำแหน่ง Tapping
Tapping position

Specifications

ขนาดที่จัดจำหน่าย Sellable dimensions [mm] unit	พื้นที่หน้าตัด Sectional area [mm ²]	มวล Mass [kg/m]	พื้นที่หน้าตัดด้านใน Moment of inertia of area Ix[mm ⁴]	
15 ~ 4,000	162.0	0.437	0.63 x 10 ⁴	0.63 x 10 ⁴

END CAP Model Number

สีดำ Color **Black**
ECP-2020-4

สีเทา Color **Gray**
ECP-2020-4-GY

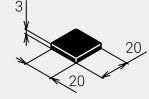

อ้างอิงหน้า 38
Reference page 38

M4



Model Number
AFS-2040-4

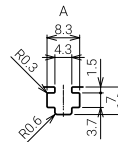
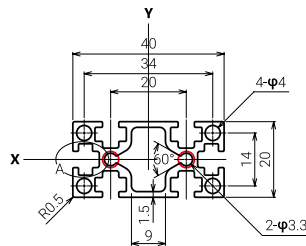

○ ตำแหน่ง Tapping
Tapping position

Specifications

ขนาดที่จัดจำหน่าย Sellable dimensions [mm] unit	พื้นที่หน้าตัด Sectional area [mm ²]	มวล Mass [kg/m]	พื้นที่หน้าตัดด้านใน Moment of inertia of area Ix[mm ⁴]	
15 ~ 4,000	278.7	0.752	1.18 x 10 ⁴	4.45 x 10 ⁴

END CAP Model Number

สีดำ Color **Black**
ECP-2040-4

สีเทา Color **Gray**
ECP-2040-4-GY

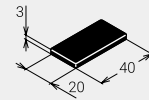

อ้างอิงหน้า 38
Reference page 38

M4



Model Number
AFS-2060-4

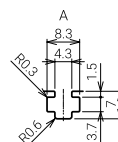
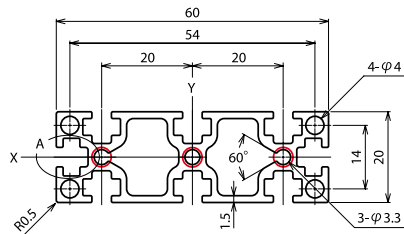

○ ตำแหน่ง Tapping
Tapping position

Specifications

ขนาดที่จัดจำหน่าย Sellable dimensions [mm] unit	พื้นที่หน้าตัด Sectional area [mm ²]	มวล Mass [kg/m]	พื้นที่หน้าตัดด้านใน Moment of inertia of area Ix[mm ⁴]	
15 ~ 4,000	403.8	1.090	1.74 x 10 ⁴	13.9 x 10 ⁴

END CAP Model Number

สีดำ Color **Black**
ECP-2060-4

สีเทา Color **Gray**
ECP-2060-4-GY

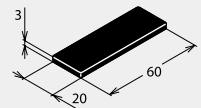

อ้างอิงหน้า 38
Reference page 38

M4



Model Number
AFS-4040-4

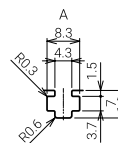
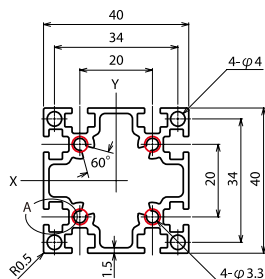

○ ตำแหน่ง Tapping
Tapping position

Specifications

ขนาดที่จัดจำหน่าย Sellable dimensions [mm] unit	พื้นที่หน้าตัด Sectional area [mm ²]	มวล Mass [kg/m]	พื้นที่หน้าตัดด้านใน Moment of inertia of area Ix[mm ⁴]	
15 ~ 4,000	439.9	1.188	7.99 x 10 ⁴	7.99 x 10 ⁴

END CAP Model Number

สีดำ Color **Black**
ECP-4040-4

สีเทา Color **Gray**
ECP-4040-4-GY

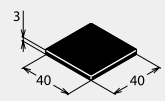

อ้างอิงหน้า 38
Reference page 38

Common Specifications

- สี Color..... Silver
- วัสดุ Material..... A6063S-T5(205) / A6N01S-T5
- ความแข็งแรง Tensile strength..... 225 N/mm²
- ชุบผิว Surface treatment..... Combined coating of anodic oxide and organic film. Acrylic resins coating by electrodeposition coating.
- หน่วยต่อชิ้น Cutting unit Milliunit
- ค่าเผื่อในการตัด Cutting tolerance..... ±0.3mm (≤2m)



Model Number
AFS-3030-6

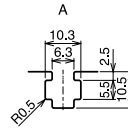
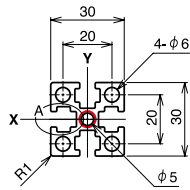

○ ตำแหน่ง Tapping
Tapping position

END CAP Model Number

สีดำ Color **Black**
ECP-3030-6
สีเทา Color **Gray**
ECP-3030-6-GY

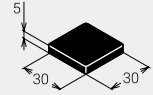

อ้างอิงหน้า 38
Reference page 38

Specifications

ขนาดที่จัดจำหน่าย Sellable dimensions [mm] unit	พื้นที่หน้าตัด Sectional area [mm ²]	มวล Mass [kg/m]	พื้นที่หน้าตัดด้านใน Moment of inertia of area	
			Ix[mm ⁴]	Iy[mm ⁴]
15 ~ 4,000	413.8	1.117	3.64 x 10 ⁴	3.64 x 10 ⁴



Model Number
AFS-3030L-6(-YE)

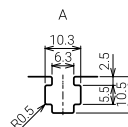
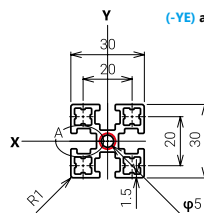

○ ตำแหน่ง Tapping
Tapping position

END CAP Model Number

สีดำ Color **Black**
ECP-3030-6
สีเทา Color **Gray**
ECP-3030-6-GY

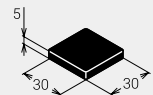

อ้างอิงหน้า 38
Reference page 38

Specifications

ขนาดที่จัดจำหน่าย Sellable dimensions [mm] unit	พื้นที่หน้าตัด Sectional area [mm ²]	มวล Mass [kg/m]	พื้นที่หน้าตัดด้านใน Moment of inertia of area	
			Ix[mm ⁴]	Iy[mm ⁴]
15 ~ 4,000	347.6	0.939	2.93 x 10 ⁴	2.93 x 10 ⁴



Model Number
AFS-3030F-6

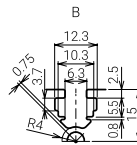
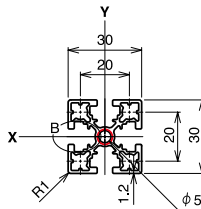

○ ตำแหน่ง Tapping
Tapping position

END CAP Model Number

สีดำ Color **Black**
ECP-3030-6
สีเทา Color **Gray**
ECP-3030-6-GY

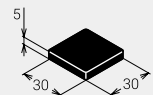

อ้างอิงหน้า 38
Reference page 38

Specifications

ขนาดที่จัดจำหน่าย Sellable dimensions [mm] unit	พื้นที่หน้าตัด Sectional area [mm ²]	มวล Mass [kg/m]	พื้นที่หน้าตัดด้านใน Moment of inertia of area	
			Ix[mm ⁴]	Iy[mm ⁴]
15 ~ 4,000	280.8	0.758	2.53 x 10 ⁴	2.53 x 10 ⁴



Model Number
AFS-3060-6

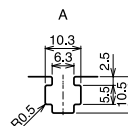
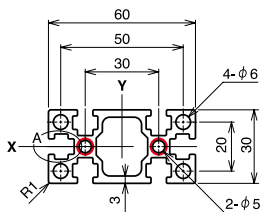

○ ตำแหน่ง Tapping
Tapping position

END CAP Model Number

สีดำ Color **Black**
ECP-3060-6
สีเทา Color **Gray**
ECP-3060-6-GY

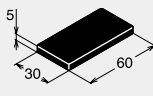

อ้างอิงหน้า 38
Reference page 38

Specifications

ขนาดที่จัดจำหน่าย Sellable dimensions [mm] unit	พื้นที่หน้าตัด Sectional area [mm ²]	มวล Mass [kg/m]	พื้นที่หน้าตัดด้านใน Moment of inertia of area	
			Ix[mm ⁴]	Iy[mm ⁴]
15 ~ 4,000	694.1	1.874	6.79 x 10 ⁴	25.6 x 10 ⁴

หมายเลขสั่งซื้อ
Ordering Code

ยกตัวอย่าง
Example

Model Number	ขนาด Measurements [mm]	*Tapping [T or W]
AFS-2020-4	— 1000	— T
AFS-2020-4	— 2000	— W
AFS-2020-4	— 3000	— W

* Tapping

T ด้านเดียว One side edge face
W สองด้าน Both sides edge face

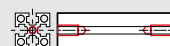

Aluminium Frame M6 series

Aluminium Frame

Bracket

Accessory

Bolts & Nuts

Rail Frame

Appendix



M6
Model Number **AFS-3060L-6(-YE)**

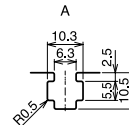
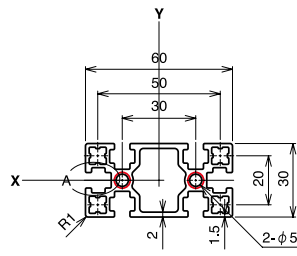

○ ตำแหน่ง Tapping Tapping position
(-YE) at the end of Model Number means product color is Yellow.

END CAP Model Number

สีดำ Color **Black**
ECP-3060-6
สีเทา Color **Gray**
ECP-3060-6-GY

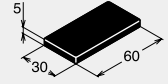

อ้างอิงหน้า 38
Reference page 38

Specifications

ขนาดที่จัดจำหน่าย Sellable dimensions [mm] unit	พื้นที่หน้าตัด Sectional area [mm ²]	มวล Mass [kg/m]	พื้นที่หน้าตัดด้านใน Moment of inertia of area	
			Ix[mm ⁴]	Iy[mm ⁴]
15 ~ 4,000	590.5	1.594	5.55 x 10 ⁴	21.3 x 10 ⁴



M6
Model Number **AFS-3060F-6**

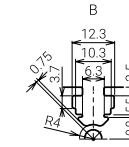
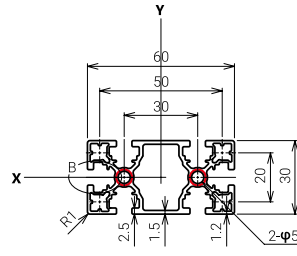

○ ตำแหน่ง Tapping Tapping position

END CAP Model Number

สีดำ Color **Black**
ECP-3060-6
สีเทา Color **Gray**
ECP-3060-6-GY

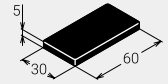

อ้างอิงหน้า 38
Reference page 38

Specifications

ขนาดที่จัดจำหน่าย Sellable dimensions [mm] unit	พื้นที่หน้าตัด Sectional area [mm ²]	มวล Mass [kg/m]	พื้นที่หน้าตัดด้านใน Moment of inertia of area	
			Ix[mm ⁴]	Iy[mm ⁴]
15 ~ 4,000	474.1	1.280	4.72 x 10 ⁴	17.5 x 10 ⁴



M6
Model Number **AFS-3090-6**

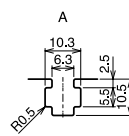
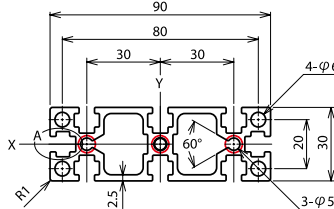

○ ตำแหน่ง Tapping Tapping position

END CAP Model Number

สีดำ Color **Black**
ECP-3090-6
สีเทา Color **Gray**
ECP-3090-6-GY

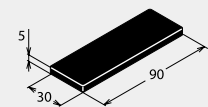

อ้างอิงหน้า 38
Reference page 38

Specifications

ขนาดที่จัดจำหน่าย Sellable dimensions [mm] unit	พื้นที่หน้าตัด Sectional area [mm ²]	มวล Mass [kg/m]	พื้นที่หน้าตัดด้านใน Moment of inertia of area	
			Ix[mm ⁴]	Iy[mm ⁴]
15 ~ 4,000	1000.6	2.702	9.85 x 10 ⁴	79.0 x 10 ⁴



M6
Model Number **AFS-30120-6**

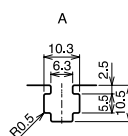
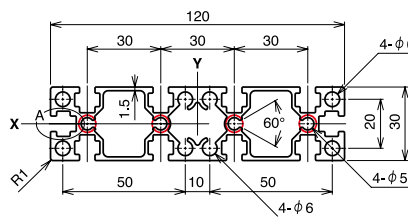

○ ตำแหน่ง Tapping Tapping position

END CAP Model Number

สีดำ Color **Black**
ECP-3060-6
(2 pieces)
สีเทา Color **Gray**
ECP-3060-6-GY
(2 pieces)

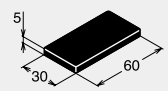

อ้างอิงหน้า 38
Reference page 38

Specifications

ขนาดที่จัดจำหน่าย Sellable dimensions [mm] unit	พื้นที่หน้าตัด Sectional area [mm ²]	มวล Mass [kg/m]	พื้นที่หน้าตัดด้านใน Moment of inertia of area	
			Ix[mm ⁴]	Iy[mm ⁴]
15 ~ 4,000	1061.9	2.867	11.6 x 10 ⁴	156.2 x 10 ⁴

Common Specifications

- สี Color..... Silver
- วัสดุ Material..... A6063S-T5(205) / A6N01S-T5
- ความแข็งแรง Tensile strength..... 225 N/mm²
- ชุบผิว Surface treatment..... Combined coating of anodic oxide and organic film. Acrylic resins coating by electrodeposition coating.
- หน่วยต่อชิ้น Cutting unit Milliunit
- ค่าเผื่อในการตัด Cutting tolerance..... ±0.3mm (≤2m)



Model Number
AFS-6060-6

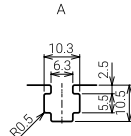
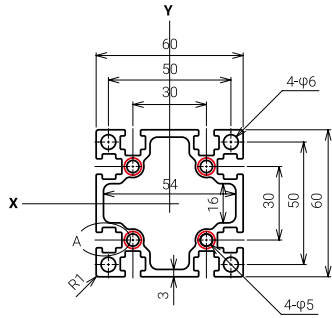

○ ตำแหน่ง Tapping
Tapping position

END CAP Model Number

สีดำ Color **Black**
ECP-6060-6
สีเทา Color **Gray**
ECP-6060-6-GY



สีดำ

อ้างอิงหน้า 38
Reference page 38

Specifications

ขนาดที่จัดจำหน่าย Sellable dimensions [mm] unit	พื้นที่หน้าตัด Sectional area [mm ²]	มวล Mass [kg/m]	พื้นที่หน้าตัดด้านใน Moment of inertia of area	
			Ix[mm ⁴]	Iy[mm ⁴]
15 ~ 4,000	1039.0	2.805	44.3 x 10 ⁴	44.3 x 10 ⁴



Model Number
AFS-6060L-6

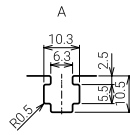
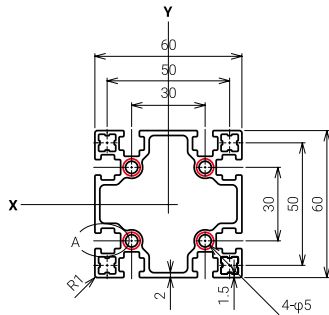

○ ตำแหน่ง Tapping
Tapping position

END CAP Model Number

สีดำ Color **Black**
ECP-6060-6
สีเทา Color **Gray**
ECP-6060-6-GY

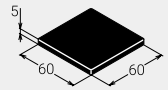

สีดำ

อ้างอิงหน้า 38
Reference page 38

Specifications

ขนาดที่จัดจำหน่าย Sellable dimensions [mm] unit	พื้นที่หน้าตัด Sectional area [mm ²]	มวล Mass [kg/m]	พื้นที่หน้าตัดด้านใน Moment of inertia of area	
			Ix[mm ⁴]	Iy[mm ⁴]
15 ~ 4,000	892.3	2.409	37.3 x 10 ⁴	37.3 x 10 ⁴



Model Number
AFS-6060F-6

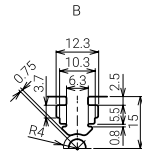
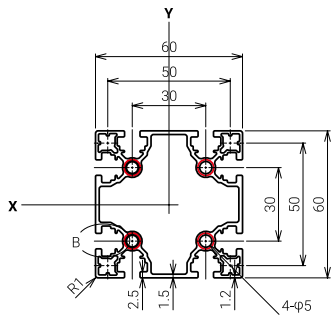

○ ตำแหน่ง Tapping
Tapping position

END CAP Model Number

สีดำ Color **Black**
ECP-6060-6
สีเทา Color **Gray**
ECP-6060-6-GY

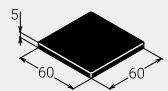

สีดำ

อ้างอิงหน้า 38
Reference page 38

Specifications

ขนาดที่จัดจำหน่าย Sellable dimensions [mm] unit	พื้นที่หน้าตัด Sectional area [mm ²]	มวล Mass [kg/m]	พื้นที่หน้าตัดด้านใน Moment of inertia of area	
			Ix[mm ⁴]	Iy[mm ⁴]
15 ~ 4,000	696.9	1.882	29.9 x 10 ⁴	29.9 x 10 ⁴



Model Number
AFS-6090B-6

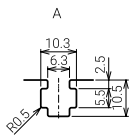
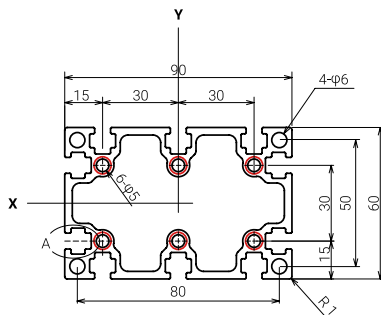

○ ตำแหน่ง Tapping
Tapping position

END CAP Model Number

สีดำ Color **Black**
ECP-6090-6
สีเทา Color **Gray**
ECP-6090-6-GY



อ้างอิงหน้า 38
Reference page 38

Specifications

ขนาดที่จัดจำหน่าย Sellable dimensions [mm] unit	พื้นที่หน้าตัด Sectional area [mm ²]	มวล Mass [kg/m]	พื้นที่หน้าตัดด้านใน Moment of inertia of area	
			Ix[mm ⁴]	Iy[mm ⁴]
15 ~ 4,000	1464.3	3.954	61.5 x 10 ⁴	132.6 x 10 ⁴

หมายเลขสั่งซื้อ
Ordering Code

ยกตัวอย่าง
Example

Model Number

AFS-2020-4
AFS-2020-4
AFS-2020-4

ขนาด
Measurements
[mm]

— 1000
— 2000
— 3000

*Tapping
[T or W]

— T
— W

*Tapping

T ด้านเดียว One side edge face

W สองด้าน Both sides edge face



Aluminium Frame M6 M8 series

Aluminium Frame

Bracket

Accessory

Bolts & Nuts

Rail Frame

Appendix



Model Number
AFSB-15120-6

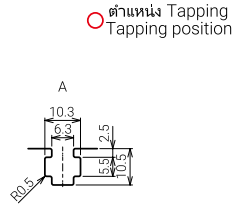
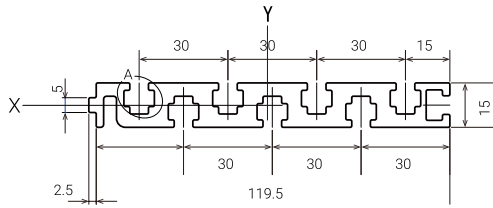

END CAP Model Number

สีดำ Color **Black**
ECP-1560-6
(2 pieces)

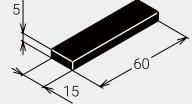

อ้างอิงหน้า 38
Reference page 38

Specifications

ขนาดที่จัดจำหน่าย Sellable dimensions [mm] unit	พื้นที่หน้าตัด Sectional area [mm ²]	มวล Mass [kg/m]	พื้นที่หน้าตัดคานใน Moment of inertia of area	
			Ix[mm ⁴]	Iy[mm ⁴]
15 ~ 4,000	280.8	0.758	2.53 x 10 ⁴	2.53 x 10 ⁴

Common Specifications

- สี Color..... Silver
- วัสดุ Material..... A6063S-T5(205) / A6N01S-T5
- ทนแรงดึง Tensile strength..... 225 N/mm²
- ชุบผิว Surface treatment..... Combined coating of anodic oxide and organic film. Acrylic resins coating by electrodeposition coating.
- หน่วยต่อชิ้น Cutting unit Milliunit
- ค่าเผื่อในการตัด Cutting tolerance..... ±0.3mm (≤2m)

M8



Model Number
AFS-4040-8

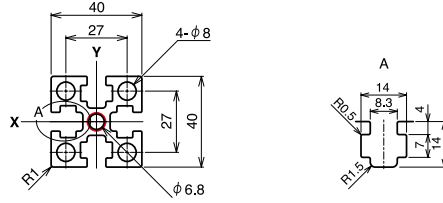

○ ตำแหน่ง Tapping
Tapping position

END CAP Model Number

สีดำ Color **Black**
ECP-4040-8
สีเทา Color **Gray**
ECP-4040-8-GY

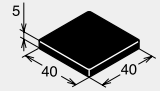

อ้างอิงหน้า 38
Reference page 38

Specifications

ขนาดที่จัดจำหน่าย Sellable dimensions [mm] unit	พื้นที่หน้าตัด Sectional area [mm ²]	มวล Mass [kg/m]	พื้นที่หน้าตัดด้านใน Moment of inertia of area	
			Ix[mm ⁴]	Iy[mm ⁴]
15 ~ 4,000	740.8	2.000	11.6 x 10 ⁴	11.6 x 10 ⁴

M8



Model Number
AFS-4040L-8(-YE)

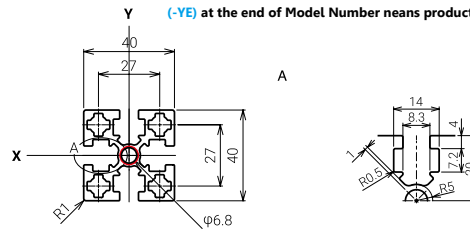

○ ตำแหน่ง Tapping
Tapping position

END CAP Model Number

สีดำ Color **Black**
ECP-4040-8
สีเทา Color **Gray**
ECP-4040-8-GY

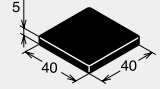

อ้างอิงหน้า 38
Reference page 38

Specifications

ขนาดที่จัดจำหน่าย Sellable dimensions [mm] unit	พื้นที่หน้าตัด Sectional area [mm ²]	มวล Mass [kg/m]	พื้นที่หน้าตัดด้านใน Moment of inertia of area	
			Ix[mm ⁴]	Iy[mm ⁴]
15 ~ 4,000	611.9	1.652	10.0 x 10 ⁴	10.0 x 10 ⁴

M8



Model Number
AFS-4040F-8

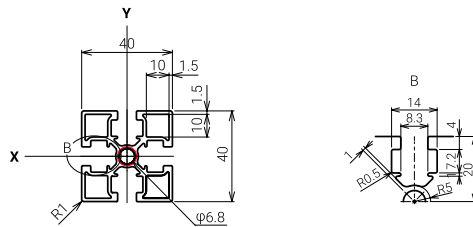

○ ตำแหน่ง Tapping
Tapping position

END CAP Model Number

สีดำ Color **Black**
ECP-4040-8
สีเทา Color **Gray**
ECP-4040-8-GY

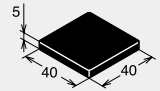

อ้างอิงหน้า 38
Reference page 38

Specifications

ขนาดที่จัดจำหน่าย Sellable dimensions [mm] unit	พื้นที่หน้าตัด Sectional area [mm ²]	มวล Mass [kg/m]	พื้นที่หน้าตัดด้านใน Moment of inertia of area	
			Ix[mm ⁴]	Iy[mm ⁴]
15 ~ 4,000	458.7	1.238	7.18 x 10 ⁴	7.18 x 10 ⁴

M8



Model Number
AFS-4080-8

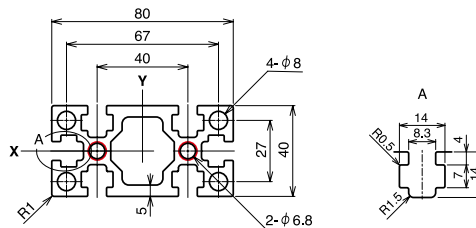

○ ตำแหน่ง Tapping
Tapping position

END CAP Model Number

สีดำ Color **Black**
ECP-4080-8
สีเทา Color **Gray**
ECP-4080-8-GY

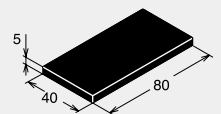

อ้างอิงหน้า 38
Reference page 38

Specifications

ขนาดที่จัดจำหน่าย Sellable dimensions [mm] unit	พื้นที่หน้าตัด Sectional area [mm ²]	มวล Mass [kg/m]	พื้นที่หน้าตัดด้านใน Moment of inertia of area	
			Ix[mm ⁴]	Iy[mm ⁴]
15 ~ 4,000	1331.7	3.596	23.2 x 10 ⁴	82.3 x 10 ⁴

หมายเลขสั่งซื้อ
Ordering Code

ยกตัวอย่าง
Example

Model Number

AFS-2020-4
AFS-2020-4
AFS-2020-4

ขนาด
Measurements
[mm]

— 1000
— 2000
— 3000

*Tapping
[T or W]

— T
— W

*Tapping

T ด้านเดียว One side edge face

W สองด้าน Both sides edge face



Aluminium Frame M8 series

Aluminium Frame

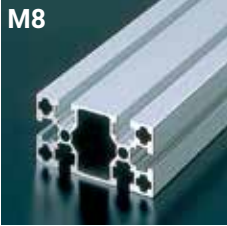

Model Number
AFS-4080L-8(-YE)

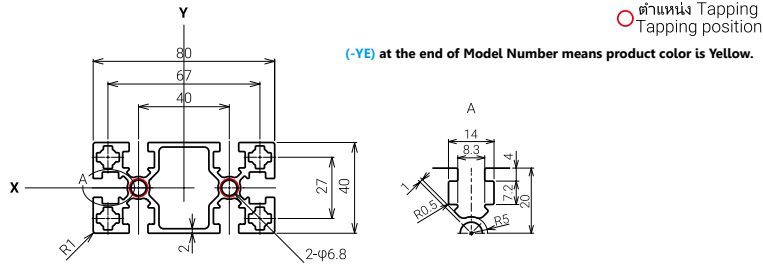

END CAP Model Number

สีดำ Color **Black**
ECP-4080-8

สีเทา Color **Gray**
ECP-4080-8-GY

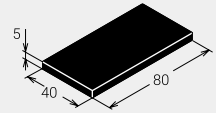

อ้างอิงหน้า 38
Reference page 38

Bracket

Accessory



Model Number
AFS-4080F-8

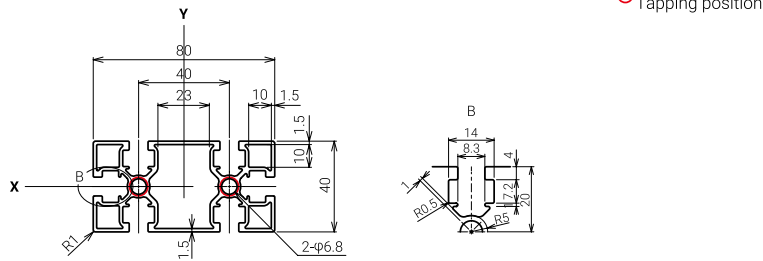

END CAP Model Number

สีดำ Color **Black**
ECP-4080-8

สีเทา Color **Gray**
ECP-4080-8-GY

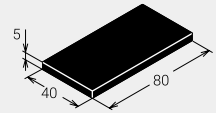

อ้างอิงหน้า 38
Reference page 38

Bolts & Nuts

Rail Frame



Model Number
AFS-40120-8

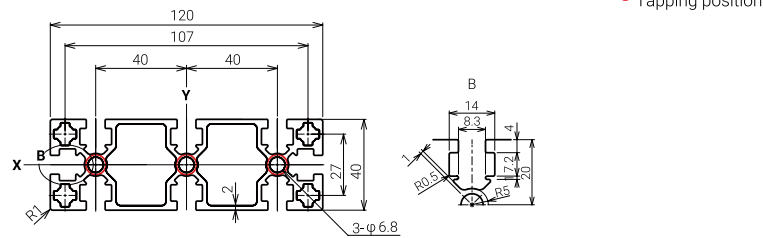

END CAP Model Number

สีดำ Color **Black**
ECP-4040-8
(3 pieces)

สีเทา Color **Gray**
ECP-4040-8-GY
(3 pieces)

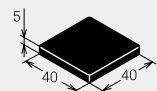

อ้างอิงหน้า 38
Reference page 38

Appendix



Model Number
AFS-8080-8

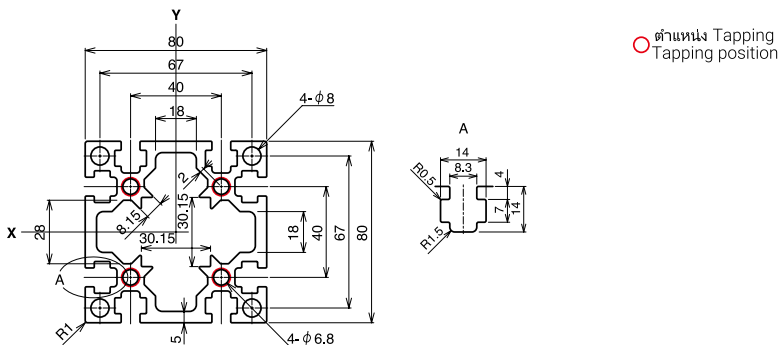

END CAP Model Number

สีดำ Color **Black**
ECP-8080-8

สีเทา Color **Gray**
ECP-8080-8-GY

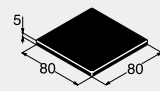

อ้างอิงหน้า 38
Reference page 38

Specifications

ขนาดที่จัดจำหน่าย Sellable dimensions [mm] unit	พื้นที่หน้าตัด Sectional area [mm ²]	มวล Mass [kg/m]	พื้นที่หน้าตัดด้านใน Moment of inertia of area Ix[mm ⁴]	
15 ~ 4,000	2144.5	5.790	153.8 x 10 ⁴	153.8 x 10 ⁴

Common Specifications

- สี Color..... Silver
- วัสดุ Material..... A6063S-T5(205) / A6N01S-T5
- ความแข็งแรง Tensile strength..... 225 N/mm2
- ชุบผิว Surface treatment..... Combined coating of anodic oxide and organic film. Acrylic resins coating by electrodeposition coating.
- หน่วยต่อชิ้น Cutting unit Milliunit
- ค่าเผื่อในการตัด Cutting tolerance..... ±0.3mm (≤2m)



Model Number
AFS-8080L-8

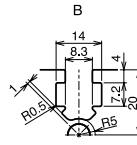
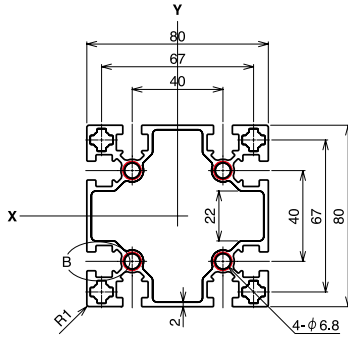

○ ตำแหน่ง Tapping
Tapping position

END CAP Model Number

สีดำ Color **Black**
ECP-8080-8

สีเทา Color **Gray**
ECP-8080-8-GY



อ้างอิงหน้า 38
Reference page 38

Specifications

ขนาดที่จัดจำหน่าย Sellable dimensions [mm] unit	พื้นที่หน้าตัด Sectional area [mm ²]	มวล Mass [kg/m]	พื้นที่หน้าตัดด้านใน Moment of inertia of area	
			Ix[mm ⁴]	Iy[mm ⁴]
15 ~ 4,000	1335.8	3.607	107.5 x 10 ⁴	107.5 x 10 ⁴



Model Number
AFS-8080F-8

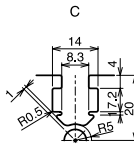
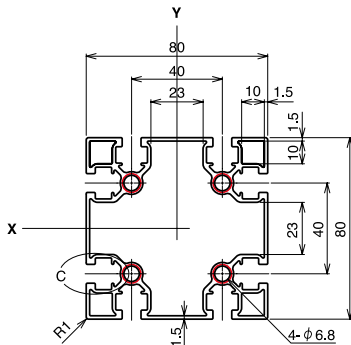

○ ตำแหน่ง Tapping
Tapping position

END CAP Model Number

สีดำ Color **Black**
ECP-8080-8

สีเทา Color **Gray**
ECP-8080-8-GY

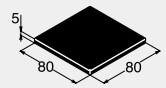

อ้างอิงหน้า 38
Reference page 38

Specifications

ขนาดที่จัดจำหน่าย Sellable dimensions [mm] unit	พื้นที่หน้าตัด Sectional area [mm ²]	มวล Mass [kg/m]	พื้นที่หน้าตัดด้านใน Moment of inertia of area	
			Ix[mm ⁴]	Iy[mm ⁴]
15 ~ 4,000	1064.9	2.875	82.5 x 10 ⁴	82.5 x 10 ⁴



Model Number
AFS-80160-8

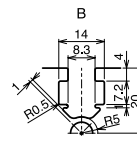
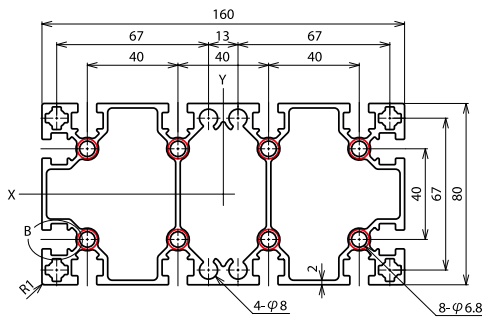

○ ตำแหน่ง Tapping
Tapping position

END CAP Model Number

สีดำ Color **Black**
ECP-8080-8

(2 pieces)
สีเทา Color **Gray**
ECP-8080-8-GY

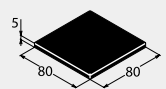

อ้างอิงหน้า 38
Reference page 38

Specifications

ขนาดที่จัดจำหน่าย Sellable dimensions [mm] unit	พื้นที่หน้าตัด Sectional area [mm ²]	มวล Mass [kg/m]	พื้นที่หน้าตัดด้านใน Moment of inertia of area	
			Ix[mm ⁴]	Iy[mm ⁴]
15 ~ 4,000	2427.9	6.555	207.6 x 10 ⁴	647.1 x 10 ⁴



Model Number
AFS-4545L-8

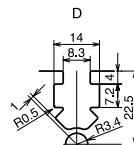
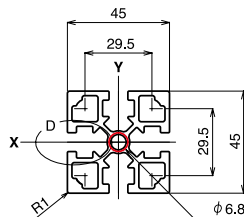

○ ตำแหน่ง Tapping
Tapping position

END CAP Model Number

สีดำ Color **Black**
ECP-4545-8



อ้างอิงหน้า 38
Reference page 38

Specifications

ขนาดที่จัดจำหน่าย Sellable dimensions [mm] unit	พื้นที่หน้าตัด Sectional area [mm ²]	มวล Mass [kg/m]	พื้นที่หน้าตัดด้านใน Moment of inertia of area	
			Ix[mm ⁴]	Iy[mm ⁴]
15 ~ 4,000	726.34	1.961	15.6 x 10 ⁴	15.6 x 10 ⁴

หมายเลขสั่งซื้อ
Ordering Code

ยกตัวอย่าง
Example

Model Number

AFS-2020-4
AFS-2020-4
AFS-2020-4

ขนาด
Measurements
[mm]

— 1000
— 2000
— 3000

*Tapping
[T or W]

— T
— W

*Tapping

T ด้านเดียว One side edge face

W สองด้าน Both sides edge face



Aluminium Frame M8 series

Aluminium Frame

Bracket

Accessory

Bolts & Nuts

Rail Frame

Appendix



M8
Model Number
AFS-4590B-8

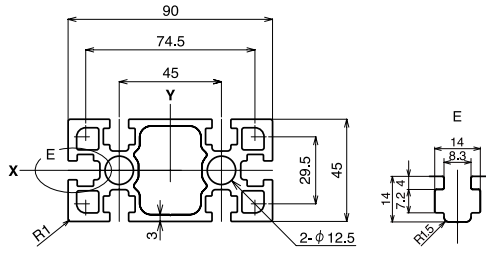

Specifications

ขนาดที่จัดจำหน่าย Sellable dimensions [mm] unit	พื้นที่หน้าตัด Sectional area [mm ²]	มวล Mass [kg/m]	พื้นที่หน้าตัดด้านใน Moment of inertia of area	
			Ix[mm ⁴]	Iy[mm ⁴]
15 ~ 4,000	1420.0	3.834	32.1 x 10 ⁴	127.6 x 10 ⁴

END CAP Model Number

สีดำ Color **Black**
ECP-4590-8

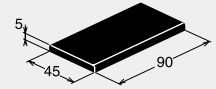

อ้างอิงหน้า 38
Reference page 38



M8
Model Number
AFS-9090L-8

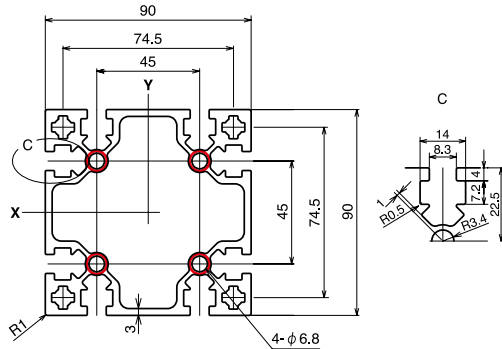

○ ตำแหน่ง Tapping
Tapping position

Specifications

ขนาดที่จัดจำหน่าย Sellable dimensions [mm] unit	พื้นที่หน้าตัด Sectional area [mm ²]	มวล Mass [kg/m]	พื้นที่หน้าตัดด้านใน Moment of inertia of area	
			Ix[mm ⁴]	Iy[mm ⁴]
15 ~ 4,000	1980.72	5.348	205.5 x 10 ⁴	205.5 x 10 ⁴

END CAP Model Number

สีดำ Color **Black**
ECP-4590-8
(2 pieces)

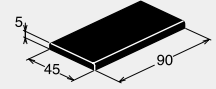

อ้างอิงหน้า 38
Reference page 38



M8
Model Number
AFS-90180L-8

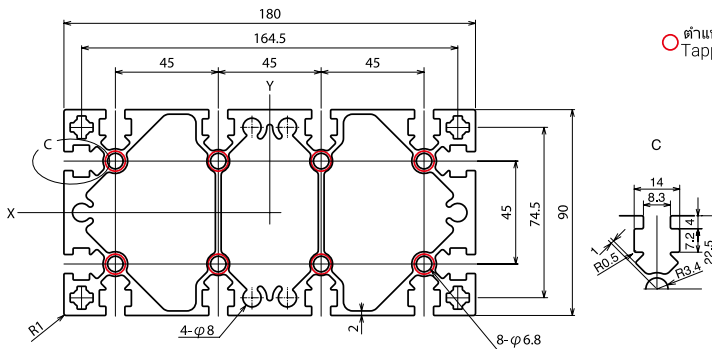

○ ตำแหน่ง Tapping
Tapping position

Specifications

ขนาดที่จัดจำหน่าย Sellable dimensions [mm] unit	พื้นที่หน้าตัด Sectional area [mm ²]	มวล Mass [kg/m]	พื้นที่หน้าตัดด้านใน Moment of inertia of area	
			Ix[mm ⁴]	Iy[mm ⁴]
15 ~ 4,000	3966.85	10.71	413.4 x 10 ⁴	1497.3 x 10 ⁴

END CAP Model Number

สีดำ Color **Black**
ECP-4590-8
(4 pieces)

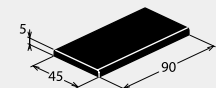

อ้างอิงหน้า 38
Reference page 38



M8
Model Number
AFS-5050-8

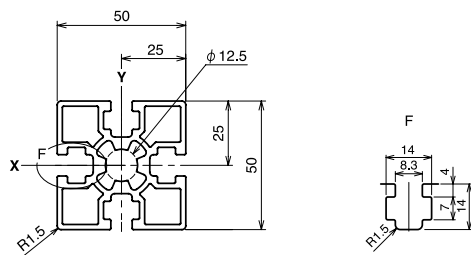

Specifications

ขนาดที่จัดจำหน่าย Sellable dimensions [mm] unit	พื้นที่หน้าตัด Sectional area [mm ²]	มวล Mass [kg/m]	พื้นที่หน้าตัดด้านใน Moment of inertia of area	
			Ix[mm ⁴]	Iy[mm ⁴]
15 ~ 4,000	815.2	2.201	18.96 x 10 ⁴	18.96 x 10 ⁴

END CAP Model Number

สีดำ Color **Black**
ECP-5050-8

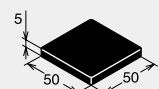

อ้างอิงหน้า 38
Reference page 38

Common Specifications

- สี Color..... Silver
- วัสดุ Material..... A6063S-T5(205) / A6N01S-T5
- ทนแรงดึง Tensile strength..... 225 N/mm²
- ซุปผิว Surface treatment..... Combined coating of anodic oxide and organic film. Acrylic resins coating by electrodeposition coating.
- หน่วยต่อชิ้น Cutting unit Milliunit
- ค่าเผื่อในการตัด Cutting tolerance..... ±0.3mm (≤2m)



Model Number
AFS-50100-8

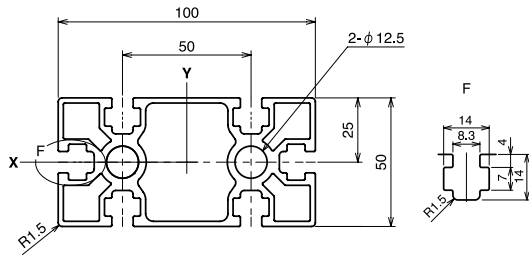

END CAP Model Number

สีดำ Color **Black**
ECP-5050-8
(2 pieces)

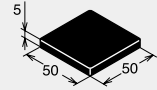

อ้างอิงหน้า 38
Reference page 38

Specifications

ขนาดที่จัดจำหน่าย Sellable dimensions [mm] unit	พื้นที่หน้าตัด Sectional area [mm ²]	มวล Mass [kg/m]	พื้นที่หน้าตัดด้านใน Moment of inertia of area	
			Ix[mm ⁴]	Iy[mm ⁴]
15 ~ 4,000	1383.7	3.736	34.42 x 10 ⁴	142.5 x 10 ⁴



Model Number
AFS-100100C-8

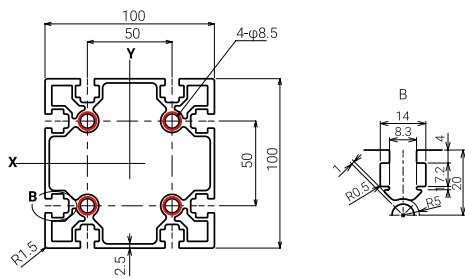

○ ตำแหน่ง Tapping
Tapping position

END CAP Model Number

สีดำ Color **Black**
ECP-100100-10

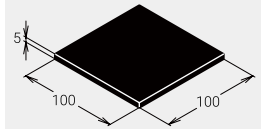

อ้างอิงหน้า 38
Reference page 38

Specifications

ขนาดที่จัดจำหน่าย Sellable dimensions [mm] unit	พื้นที่หน้าตัด Sectional area [mm ²]	มวล Mass [kg/m]	พื้นที่หน้าตัดด้านใน Moment of inertia of area	
			Ix[mm ⁴]	Iy[mm ⁴]
15 ~ 4,000	2168.7	5.855	274.87 x 10 ⁴	274.87 x 10 ⁴

หมายเลขสั่งซื้อ Ordering Code	Model Number	ขนาด Measurements [mm]	*Tapping [T or W]	*Tapping T ด้านเดียว One side edge face W สองด้าน Both sides edge face
ยกตัวอย่าง Example	AFS-2020-4	— 1000	—	T
	AFS-2020-4	— 2000	—	T
	AFS-2020-4	— 3000	—	W

Bracket Frame / Special Frame

Aluminium Frame

Bracket

Accessory

Bolts & Nuts

Appendix

Appendix

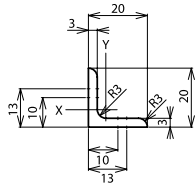
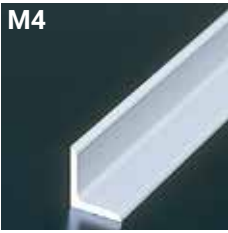

Model Number
AFL-2020-T3

Specifications

ขนาดที่จัดจำหน่าย Sellable dimensions [mm] unit	พื้นที่หน้าตัด Sectional area [mm ²]	มวล Mass [kg/m]	พื้นที่หน้าตัดด้านใน Moment of inertia of area	
			Ix[mm ⁴]	Iy[mm ⁴]
15 ~ 3,000	108.7	0.293	0.37 x 10 ⁴	0.37 x 10 ⁴

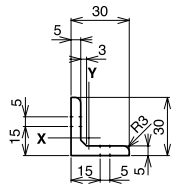
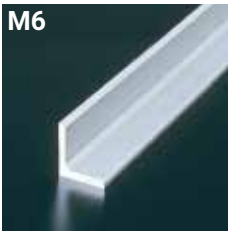

Model Number
AFL-3030

Specifications

ขนาดที่จัดจำหน่าย Sellable dimensions [mm] unit	พื้นที่หน้าตัด Sectional area [mm ²]	มวล Mass [kg/m]	พื้นที่หน้าตัดด้านใน Moment of inertia of area	
			Ix[mm ⁴]	Iy[mm ⁴]
15 ~ 3,000	274.9	0.742	2.13 x 10 ⁴	2.13 x 10 ⁴

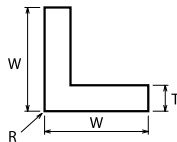

EQUAL ANGLE

Specifications

T [mm]	W [mm]	R	รุ่น Model Number	พื้นที่หน้าตัด Sectional area [mm ²]	มวล Mass [kg/m]	พื้นที่หน้าตัดด้านใน Moment of inertia of area	
						Ix[mm ⁴]	Iy[mm ⁴]
5	30	0.3	AFL-3005	275	0.743	2.22 x 10 ⁴	2.22 x 10 ⁴
	40		AFL-4005	375	1.013	5.56 x 10 ⁴	5.56 x 10 ⁴
	60		AFL-6005	575	1.553	19.9 x 10 ⁴	19.9 x 10 ⁴
	80		AFL-8005	775	2.093	48.6 x 10 ⁴	48.6 x 10 ⁴
10	30	0.3	AFL-3010	500	1.35	3.62 x 10 ⁴	3.62 x 10 ⁴
	60		AFL-6010	1100	2.97	35.5 x 10 ⁴	35.5 x 10 ⁴

ขนาดที่จัดจำหน่าย Sellable dimensions : 15~2,000 mm

Common Specifications

- สี Color..... Silver
- วัสดุ Material..... A6063S-T5(205) / A6N01S-T5
- ความแรงดึง Tensile strength..... 225 N/mm2
- ชุบผิว Surface treatment..... Combined coating of anodic oxide and organic film. Acrylic resins coating by electrodeposition coating.
- หน่วยต่อชิ้น Cutting unit Milliunit
- ค่าเผื่อในการตัด Cutting tolerance..... ±0.3mm (≤2m)

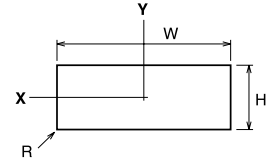
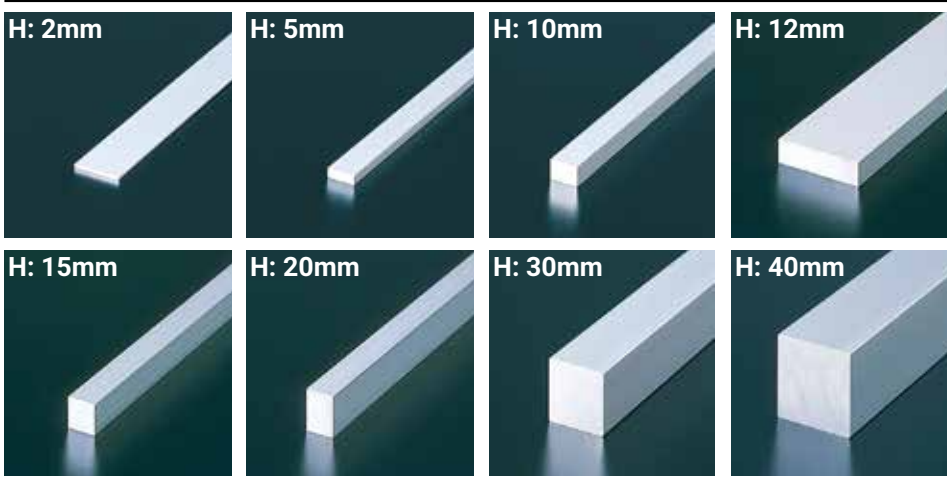

FLAT BAR

Specifications

H [mm]	W [mm]	R	รุ่น Model Number	พื้นที่หน้าตัด Sectional area [mm ²]	มวล Mass [kg/m]	พื้นที่หน้าตัดค่าใน Moment of inertia of area	
						Ix[mm ⁴]	Iy[mm ⁴]
2	25	0.3	AFFB-02502	49.8	0.134	0.002 x 10 ⁴	0.26 x 10 ⁴
	15		AFFB-01505	75	0.203	0.015 x 10 ⁴	0.14 x 10 ⁴
	30		AFFB-03005	150	0.405	0.031 x 10 ⁴	1.13 x 10 ⁴
	40		AFFB-04005	199.9	0.54	0.042 x 10 ⁴	2.66 x 10 ⁴
	45		AFFB-04505	255	0.608	0.047 x 10 ⁴	3.80 x 10 ⁴
	60		AFFB-06005	300	0.81	0.063 x 10 ⁴	8.99 x 10 ⁴
	80		AFFB-08005	400	1.08	0.083 x 10 ⁴	21.3 x 10 ⁴
	90		AFFB-09005	450	1.22	0.094 x 10 ⁴	30.4 x 10 ⁴
5	120	AFFB-12005	600	1.62	0.13 x 10 ⁴	72.0 x 10 ⁴	
	15	AFFB-01510	150	0.405	0.13 x 10 ⁴	0.28 x 10 ⁴	
	30	AFFB-03010	300	0.81	0.25 x 10 ⁴	2.25 x 10 ⁴	
	40	AFFB-04010	400	1.08	0.33 x 10 ⁴	5.33 x 10 ⁴	
	60	AFFB-06010	600	1.62	0.50 x 10 ⁴	18.0 x 10 ⁴	
	80	AFFB-08010	800	2.16	0.67 x 10 ⁴	42.7 x 10 ⁴	
	90	AFFB-09010	900	2.43	0.75 x 10 ⁴	60.7 x 10 ⁴	
	120	AFFB-12010	1200	3.24	1.00 x 10 ⁴	144.0 x 10 ⁴	
10	45	AFFB-04512	539.9	1.46	0.65 x 10 ⁴	9.11 x 10 ⁴	
	60	AFFB-06012	719.9	1.94	0.86 x 10 ⁴	21.6 x 10 ⁴	
	90	AFFB-09012	1079.9	2.92	1.30 x 10 ⁴	72.9 x 10 ⁴	
	15	AFFB-01515	225	0.608	0.42 x 10 ⁴	0.42 x 10 ⁴	
	30	AFFB-03015	450	1.22	0.84 x 10 ⁴	3.38 x 10 ⁴	
	60	AFFB-06015	900	2.43	1.69 x 10 ⁴	27.0 x 10 ⁴	
	80	AFFB-08015	1200	3.24	2.25 x 10 ⁴	64.0 x 10 ⁴	
	90	AFFB-09015	1350	3.65	2.53 x 10 ⁴	91.1 x 10 ⁴	
15	100	AFFB-10015	1499.9	4.05	2.81 x 10 ⁴	125.0 x 10 ⁴	
	120	AFFB-12015	1800	4.86	3.38 x 10 ⁴	216.0 x 10 ⁴	
	200	AFFB-20015	2999.8	8.099	5.62 x 10 ⁴	999.8 x 10 ⁴	
	250	AFFB-25015	3749.8	10.124	7.03 x 10 ⁴	1952.8 x 10 ⁴	
	15	AFFB-01520	300	0.81	1.00 x 10 ⁴	0.56 x 10 ⁴	
	20	AFFB-02020	399.8	1.08	1.33 x 10 ⁴	1.33 x 10 ⁴	
	30	AFFB-03020	600	1.62	2.00 x 10 ⁴	4.50 x 10 ⁴	
	40	AFFB-04020	800	2.16	1.89 x 10 ⁴	9.10 x 10 ⁴	
20	60	AFFB-06020	1200	3.24	4.00 x 10 ⁴	36.0 x 10 ⁴	
	80	AFFB-08020	1600	4.32	5.33 x 10 ⁴	85.3 x 10 ⁴	
	90	AFFB-09020	1800	4.86	6.00 x 10 ⁴	121.5 x 10 ⁴	
	100	AFFB-10020	2000	5.4	6.66 x 10 ⁴	166.6 x 10 ⁴	
	120	AFFB-12020	2400	6.8	8.00 x 10 ⁴	288.0 x 10 ⁴	
	200	AFFB-20020	3999.8	10.8	13.3 x 10 ⁴	1333.1 x 10 ⁴	
	250	AFFB-25020	4999.8	13.5	16.7 x 10 ⁴	2603.8 x 10 ⁴	
	30	AFFB-03030	899.1	2.43	6.73 x 10 ⁴	6.73 x 10 ⁴	
30	60	AFFB-06030	1799.1	4.86	13.5 x 10 ⁴	53.9 x 10 ⁴	
	40	AFFB-04040	1599.1	4.32	21.3 x 10 ⁴	21.3 x 10 ⁴	
40	80	AFFB-08040	3199.1	8.64	42.6 x 10 ⁴	170.5 x 10 ⁴	

ขนาดที่จัดจำหน่าย Sellable dimensions : 15-2,000 mm

หมายเลขสั่งซื้อ Ordering Code	Model Number	ขนาด Measurements [mm]
ยกตัวอย่าง Example	AFL-3030	— 100
	AFL-3030	— 200
	AFL-3030	— 300

Bracket

M4

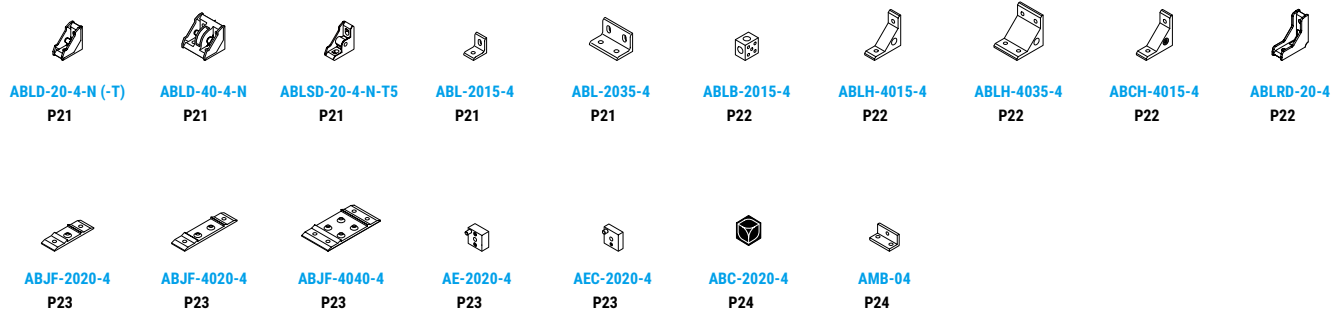

M6

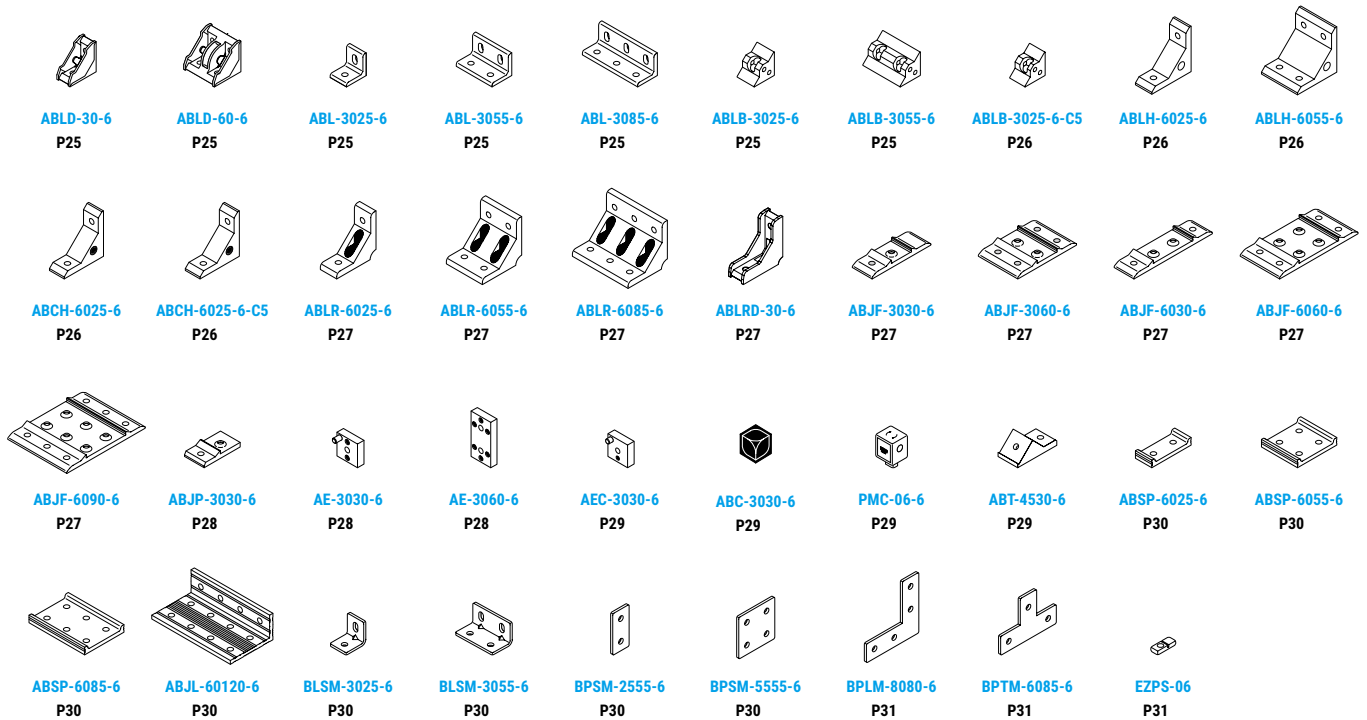

M8

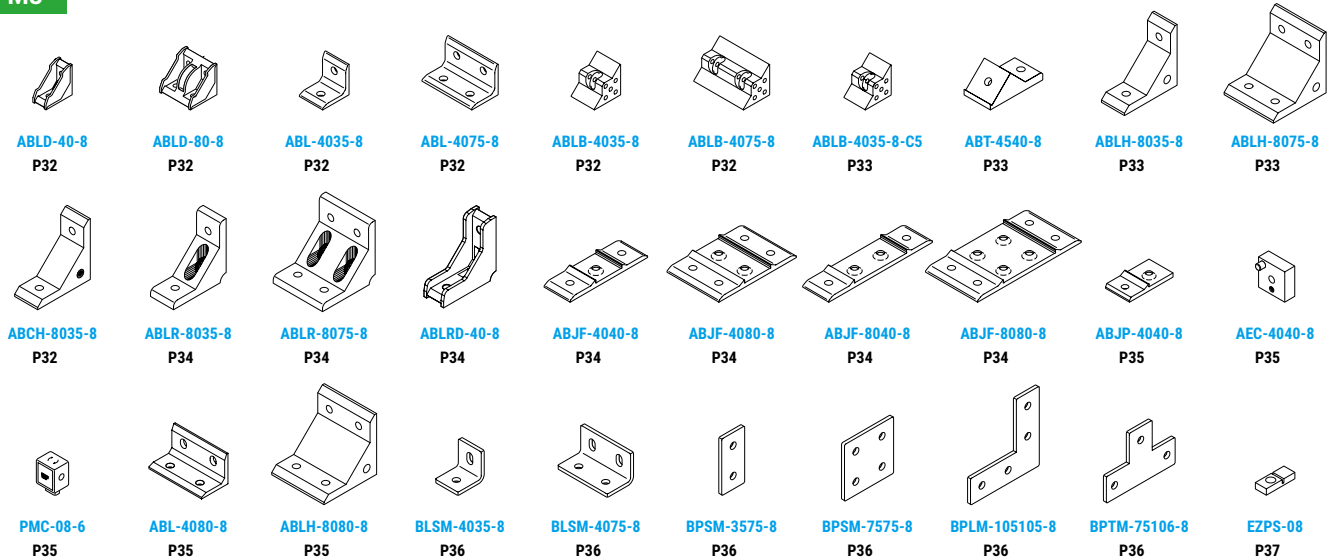

Bracket M4 series

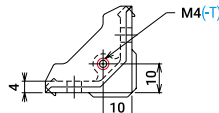
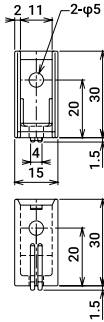

(-T) at the end of Model Number means one side M4 tapping.

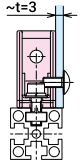
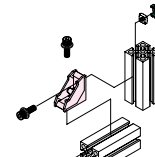

Example of use

Model Number
ABLD-20-4-N(-T)

Specifications

Model Number	วัสดุ Material	ผิว Surface treatment	มวล Mass [g]	จำนวน Bolt Model Number	Recommended Fastening Parts	
					จำนวน Nut Model Number	จำนวน Nut Holder Model Number
ABLD-20-4(-T) ABLD-20-4-N(-T)	ADC-12	Baking finish —	12	CSW-04-12 (2 pieces)	NSM-04-4 (2 pieces)	NH-04-GR (2 pieces)

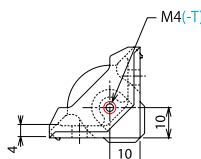
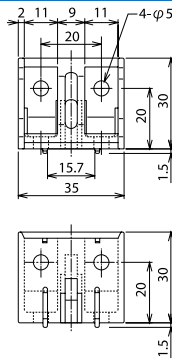

(-T) at the end of Model Number means one side M4 tapping.

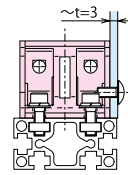
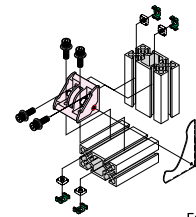

Example of use

Model Number
ABLD-40-4-N

Specifications

Model Number	วัสดุ Material	ผิว Surface treatment	มวล Mass [g]	จำนวน Bolt Model Number	Recommended Fastening Parts	
					จำนวน Nut Model Number	จำนวน Nut Holder Model Number
ABLD-40-4-N	ADC-12	—	26	CSW-04-12 (4 pieces)	NSM-04-4 (4 pieces)	NH-04-GR (4 pieces)

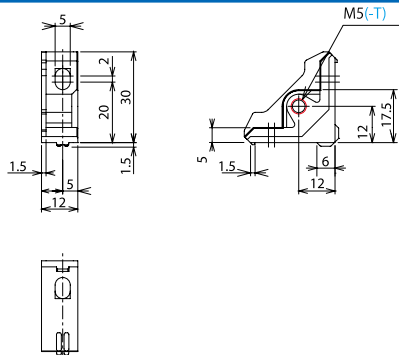

M5(-T)

(-T) at the end of Model Number means one side M4 tapping.

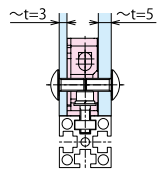
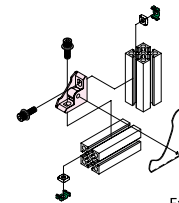

Example of use

Model Number
ABLS-20-4-N-T5

Specifications

Model Number	วัสดุ Material	ผิว Surface treatment	มวล Mass [g]	จำนวน Bolt Model Number	Recommended Fastening Parts	
					จำนวน Nut Model Number	จำนวน Nut Holder Model Number
ABLS-20-4-N-T5	ADC-12	—	11.6	CSW-04-12 (2 pieces)	NSM-04-4 (2 pieces)	NH-04-GR (2 pieces)

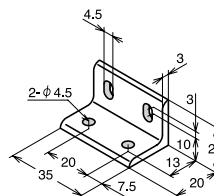
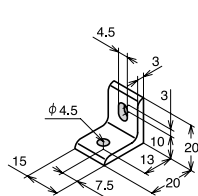

Model Number
ABL-2015-4

Model Number
ABL-2035-4

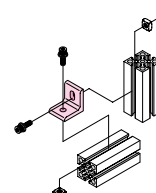

Example of use

Specifications

Model Number	วัสดุ Material	ผิว Surface treatment	มวล Mass [g]	จำนวน Bolt Model Number	Recommended Fastening Parts	
					จำนวน Nut Model Number	จำนวน Nut Holder Model Number
ABL-2015-4 ABL-2035-4	A6N01S-T5	Anodize	4 9	CSW-04-10 (2 pieces) CSW-04-10 (4 pieces)	NSM-04-4 (2 pieces) NSM-04-4 (4 pieces)	NH-04-GR (2 pieces) NH-04-GR (4 pieces)

Threaded fastener

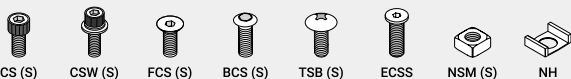

Bracket M4 series

Aluminium Frame

Bracket

Accessory

Bolts & Nuts

Rail Frame

Appendix



Model Number
ABLB-2015-4(-T)

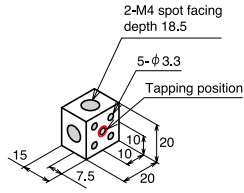

(-T) at the end of Model Number means one side M4 tapping.

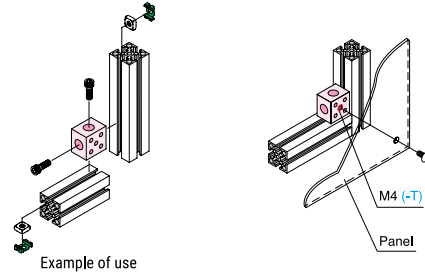

Specifications

Model Number	วัสดุ Material	ผิว Surface treatment	มวล Mass [g]	รุ่น Bolt Model Number	Recommended Fastening Parts รุ่น Nut Model Number	รุ่น Nut Holder Model Number
ABLB-2015-4 ABLB-2015-4-T	A6063S-T5 / A6N01S-T5	Anodize	10	CSW-04-08 (2 pieces)	NSM-04-4 (2 pieces)	NH-04-GR (2 pieces)

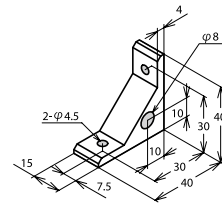

Model Number
ABLH-4015-4

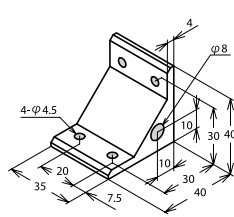

Model Number
ABLH-4035-4

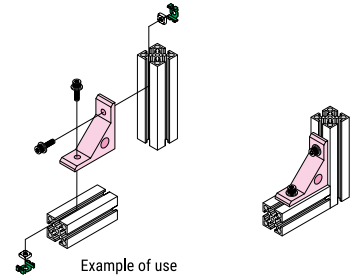

Specifications

Model Number	วัสดุ Material	ผิว Surface treatment	มวล Mass [g]	รุ่น Bolt Model Number	Recommended Fastening Parts รุ่น Nut Model Number	รุ่น Nut Holder Model Number
ABLH-4015-4 ABLH-4035-4	A6063S-T5 / A6N01S-T5	Anodize	18 41	CSW-04-12 (2 pieces) CSW-04-12 (4 pieces)	NSM-04-4 (2 pieces) NSM-04-4 (4 pieces)	NH-04-GR (2 pieces) NH-04-GR (4 pieces)



Model Number
ABCH-4015-4

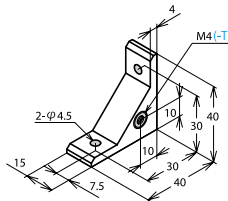

(-T) at the end of Model Number means one side M4 tapping.

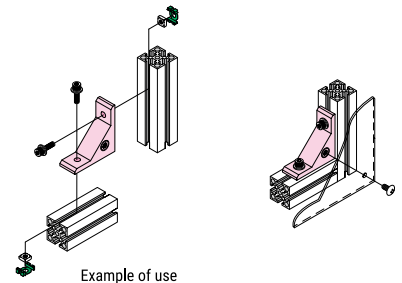

Specifications

Model Number	วัสดุ Material	ผิว Surface treatment	มวล Mass [g]	รุ่น Bolt Model Number	Recommended Fastening Parts รุ่น Nut Model Number	รุ่น Nut Holder Model Number
ABCH-4015-4	A6063S-T5 / A6N01S-T5	Anodize	20	CSW-04-12 (2 pieces)	NSM-04-4 (2 pieces)	NH-04-GR (2 pieces)



Model Number
ABLRD-20-4

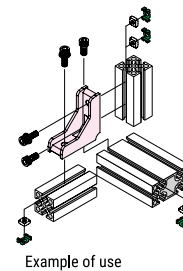
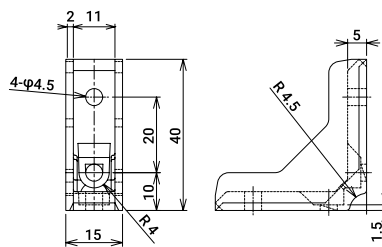

Specifications

Model Number	วัสดุ Material	ผิว Surface treatment	มวล Mass [g]	รุ่น Bolt Model Number	Recommended Fastening Parts รุ่น Nut Model Number	รุ่น Nut Holder Model Number
ABLRD-20-4	ADC-12	Baking finish	15.5	CSW-04-12 (2 pieces) CS-04-08 (2 pieces)	NSM-04-4 (4 pieces)	NH-04-GR (4 pieces)

Threaded fastener

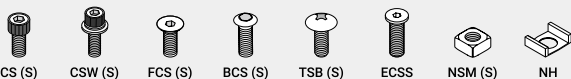



Model Number
ABJF-2020-4

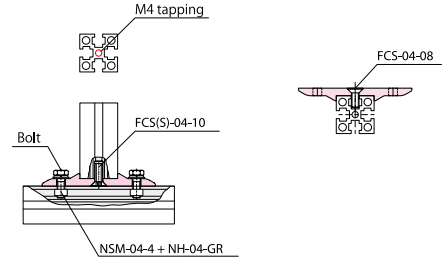
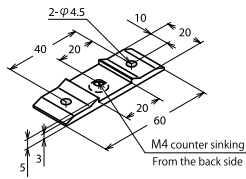

Specifications

รุ่น Model Number	วัสดุ Material	ผิว Surface treatment	มวล Mass [g]	Recommended Fastening Parts		
				รุ่น Bolt Model Number	รุ่น Nut Model Number	รุ่น Nut Holder Model Number
ABJF-2020-4	A6N01S-T5	Anodize treatment Clear coat	9	CSW-04-10 (2 pieces) FCS-04-10	NSM-04-4 (2 pieces)	NH-04-GR (2 pieces)

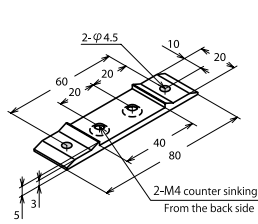

Model Number
ABJF-4020-4

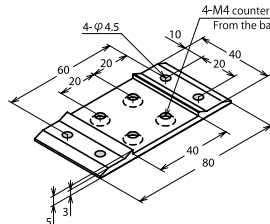

Model Number
ABJF-4040-4

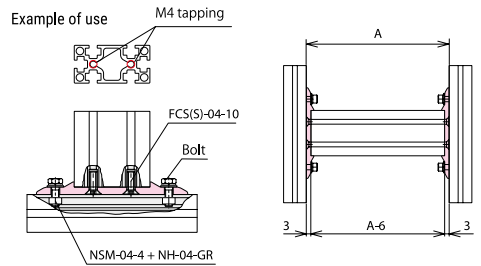

Specifications

รุ่น Model Number	วัสดุ Material	ผิว Surface treatment	มวล Mass [g]	Recommended Fastening Parts		
				รุ่น Bolt Model Number	รุ่น Nut Model Number	รุ่น Nut Holder Model Number
ABJF-4020-4	A6N01S-T5	Anodize treatment Clear coat	12	CSW-04-10 (2 pieces) FCS-04-10 (2 pieces)	NSM-04-4 (2 pieces)	NH-04-GR (2 pieces)
ABJF-4040-4			24	CSW-04-10 (2 pieces) FCS-04-10 (2 pieces)	NSM-04-4 (4 pieces)	NH-04-GR (4 pieces)



Model Number
AE-2020-4

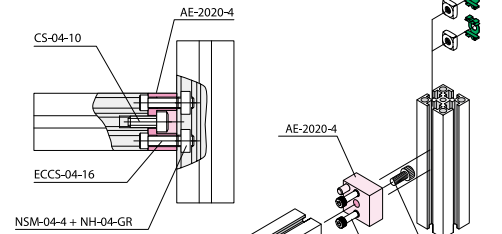
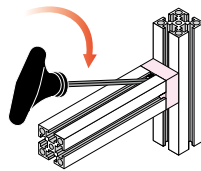
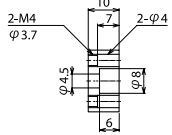
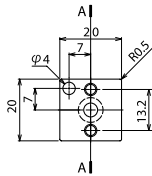

Example of use

Specifications

รุ่น Model Number	วัสดุ Material	ผิว Surface treatment	มวล Mass [g]	Recommended Fastening Parts		
				รุ่น Bolt Model Number	รุ่น Nut Model Number	รุ่น Nut Holder Model Number
AE-2020-4	A6063S-T5 / A6N01S-T5	Anodize treatment Clear coat	11	CS-04-10 ECCS-04-16	NSM-04-4	NH-04-GR



Model Number
AEC-2020-4

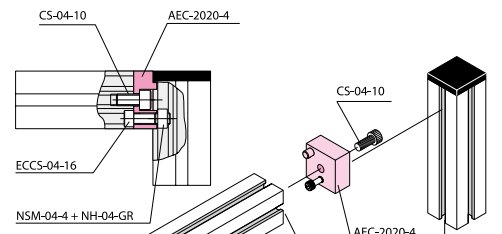
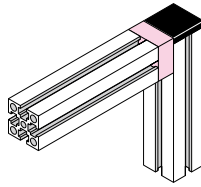
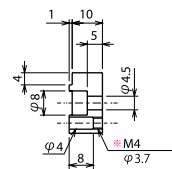
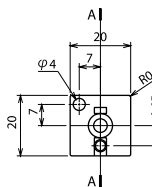

Specifications

รุ่น Model Number	วัสดุ Material	ผิว Surface treatment	มวล Mass [g]	Recommended Fastening Parts		
				รุ่น Bolt Model Number	รุ่น Nut Model Number	รุ่น Nut Holder Model Number
AEC-2020-4	A6063S-T5 / A6N01S-T5	Anodize treatment Clear coat	11	CS-04-10 ECCS-04-16	NSM-04-4	NH-04-GR

Bracket M4 series

Aluminium Frame

Bracket

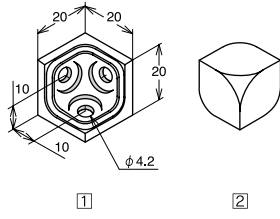

Model Number
ABC-2020-4

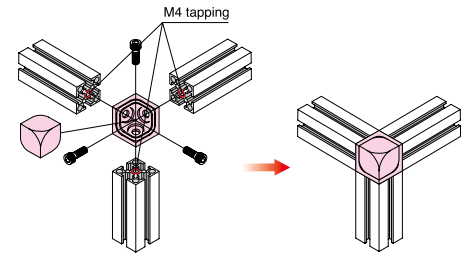

Example of use

Specifications

รุ่น Model Number	วัสดุ Material	ผิว Surface treatment	มวล Mass [g]	Recommended Fastening Parts รุ่น เกราะ Bolt Model Number
ABC-2020-4	① ADC-12 ② PA ③ PA	Baking finish	14.4	CS-04-8 (3 pieces)

Accessory

Bolts & Nuts

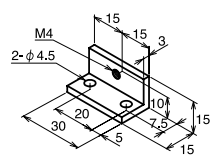

Model Number
AMB-04

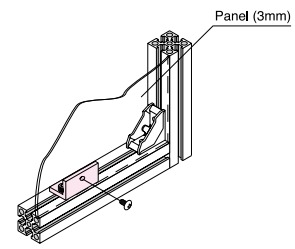

Example of use

Specifications

รุ่น Model Number	วัสดุ Material	ผิว Surface treatment	มวล Mass [g]	Recommended Fastening Parts		
				รุ่น เกราะ Bolt Model Number	รุ่น น็อต Nut Model Number	รุ่น แผ่นรองน็อต Nut Holder Model Number
AMB-04	A6063S-T5 / A6N01S-T5	Anodize	5.9	CSW-04-08 (2 pieces)	NSM-04-4 (2 pieces)	NH-04-GR (2 pieces)

Rail Frame

Appendix

Threaded fastener

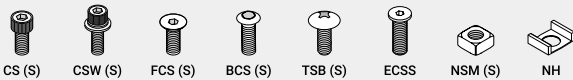

Bracket M6 series



Model Number
ABLD-30-6-N(-T)

Specifications

Model Number	Material	Surface treatment	Mass [g]	Recommended Fastening Parts		
				Bolt Model Number	Nut Model Number	Nut Holder Model Number
ABLD-30-6-N	ADC-12	—	29	CSW-06-18 (2 pieces)	NSM-06-6 (2 pieces)	NH-06-GR (2 pieces)
ABLD-30-6-N-T						

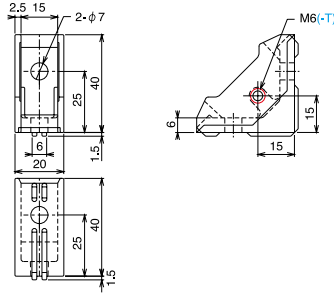

(-T) at the end of Model Number means one side M6 tapping.

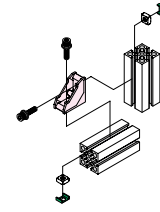

Example of use

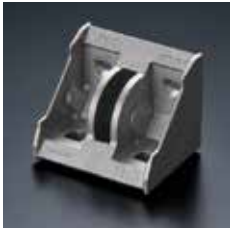

Model Number
ABLD-60-6-N(-T)

Specifications

Model Number	Material	Surface treatment	Mass [g]	Recommended Fastening Parts		
				Bolt Model Number	Nut Model Number	Nut Holder Model Number
ABLD-60-6-N	ADC-12	—	65	CSW-06-18 (4 pieces)	NSM-06-6 (4 pieces)	NH-06-GR (4 pieces)
ABLD-60-6-N-T						

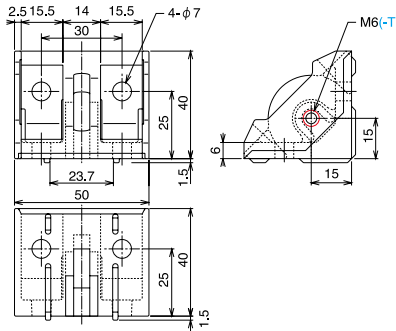

(-T) at the end of Model Number means one side M6 tapping.

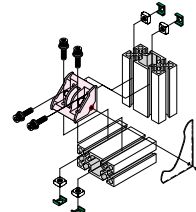

Example of use



Model Number
ABL-3025-6

Model Number
ABL-3055-6

Model Number
ABL-3085-6

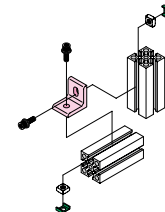
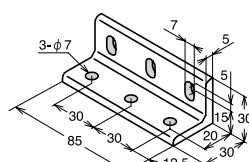
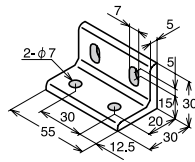
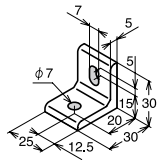

Example of use

Specifications

Model Number	Material	Surface treatment	Mass [g]	Recommended Fastening Parts		
				Bolt Model Number	Nut Model Number	Nut Holder Model Number
ABL-3025-6	A6N01S-T5	Anodize	16	CSW-06-15 (2 pieces)	NSM-06-6 (2 pieces)	NH-06-GR (2 pieces)
ABL-3055-6			36	CSW-06-15 (4 pieces)	NSM-06-6 (4 pieces)	NH-06-GR (4 pieces)
ABL-3085-6			56	CSW-06-15 (6 pieces)	NSM-06-6 (6 pieces)	NH-06-GR (6 pieces)



Model Number
ABLB-3025-6(-T)

Model Number
ABLB-3055-6(-T)

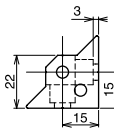
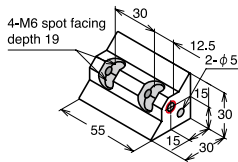
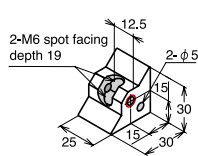

(-T) at the end of Model Number means one side M6 tapping.

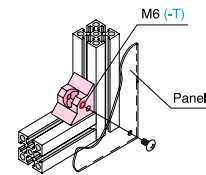

Example of use

Specifications

Model Number	Material	Surface treatment	Mass [g]	Recommended Fastening Parts		
				Bolt Model Number	Nut Model Number	Nut Holder Model Number
ABLB-3025-6(-T)	A6063S-T5 / A6N01S-T5	Anodize	27	CS-06-12 (2 pieces)	NSM-06-6 (2 pieces)	NH-06-GR (2 pieces)
ABLB-3055-6(-T)			60	CS-06-12 (4 pieces)	NSM-06-6 (4 pieces)	NH-06-GR (4 pieces)

Bracket M6 series

Aluminium Frame

Bracket

Accessory

Bolts & Nuts

Rail Frame

Appendix



Model Number
ABLB-3025-6-C5

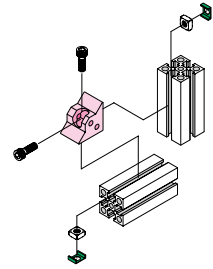
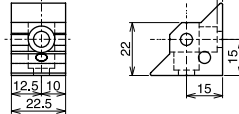
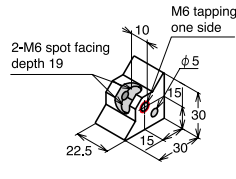

Example of use

Specifications

Model Number	วัสดุ Material	ผิว Surface treatment	มวล Mass [g]	รุ่น Bolt Model Number	Recommended Fastening Parts รุ่น Nut Model Number	รุ่น Nut Holder Model Number
ABLB-3025-6-C5	A6063S-T5 / A6N01S-T5	Anodize	23	CS-06-12 (2 pieces)	NSM-06-6 (2 pieces)	NH-06-GR (2 pieces)

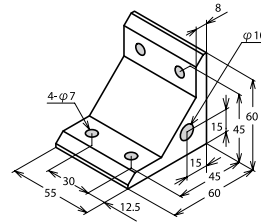
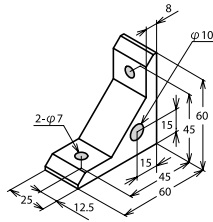

Model Number
ABLH-6025-6

Model Number
ABLH-6055-6

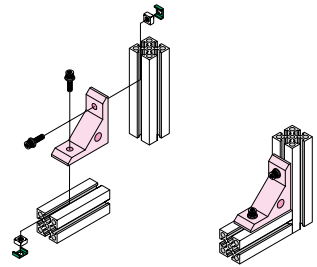

Example of use

Specifications

Model Number	วัสดุ Material	ผิว Surface treatment	มวล Mass [g]	รุ่น Bolt Model Number	Recommended Fastening Parts รุ่น Nut Model Number	รุ่น Nut Holder Model Number
ABLH-6025-6	A6063S-T5 / A6N01S-T5	Anodize	74	CSW-06-20 (2 pieces)	NSM-06-6 (2 pieces)	NH-06-GR (2 pieces)
ABLH-6055-6			162	CSW-06-20 (4 pieces)	NSM-06-6 (4 pieces)	NH-06-GR (4 pieces)



Model Number
ABCH-6025-6

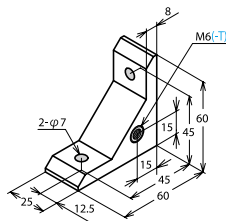

(-T) at the end of Model Number means one side M6 tapping.

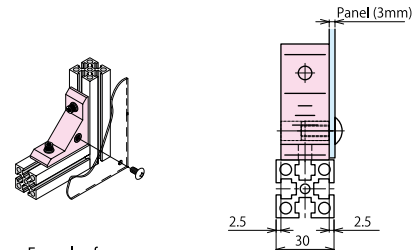

Example of use

Specifications

Model Number	วัสดุ Material	ผิว Surface treatment	มวล Mass [g]	รุ่น Bolt Model Number	Recommended Fastening Parts รุ่น Nut Model Number	รุ่น Nut Holder Model Number
ABCH-6025-6	A6063S-T5 / A6N01S-T5 Bush: SUS303	Anodize	79	CS-06-20 (2 pieces)	NSM-06-6 (2 pieces)	NH-06-GR (2 pieces)



Model Number
ABCH-6025-6-C5

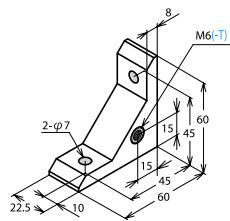

(-T) at the end of Model Number means one side M6 tapping.

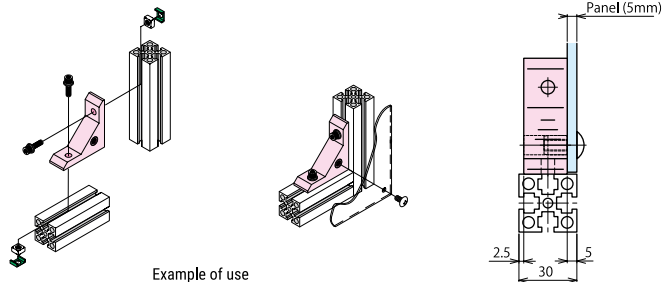

Example of use

Specifications

Model Number	วัสดุ Material	ผิว Surface treatment	มวล Mass [g]	รุ่น Bolt Model Number	Recommended Fastening Parts รุ่น Nut Model Number	รุ่น Nut Holder Model Number
ABCH-6025-6-C5	A6063S-T5 / A6N01S-T5 Bush: SUS303	Anodize	71	CSW-06-20 (2 pieces)	NSM-06-6 (2 pieces)	NH-06-GR (2 pieces)

Threaded fastener

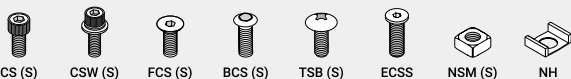

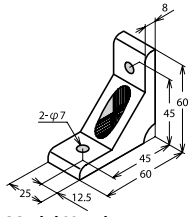

Model Number
ABLR-6025-6

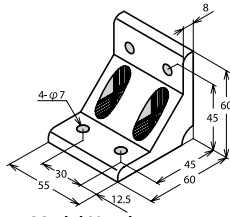

Model Number
ABLR-6055-6

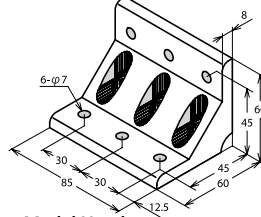

Model Number
ABLR-6085-6

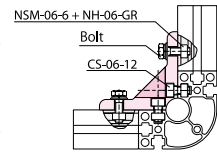

Example of use

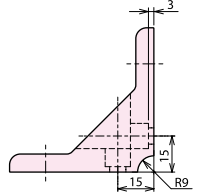

Specifications

รุ่น Model Number	วัสดุ Material	ชุบผิว Surface treatment	มวล Mass [g]	Recommended Fastening Parts		
				รุ่นโบลท์ Bolt Model Number	รุ่น น็อต Nut Model Number	รุ่น แผ่นรองน็อต Nut Holder Model Number
ABLR-6025-6	A6063S-T5 / A6N01S-T5	Anodize	65	CSW-06-20 (2 pieces) / CS-06-12 (2 pieces)	NSM-06-6 (4 pieces)	NH-06-GR (4 pieces)
ABLR-6055-6			146	CSW-06-20 (4 pieces) / CS-06-12 (4 pieces)	NSM-06-6 (8 pieces)	NH-06-GR (8 pieces)
ABLR-6085-6			227	CSW-06-20 (6 pieces) / CS-06-12 (6 pieces)	NSM-06-6 (12 pieces)	NH-06-GR (12 pieces)

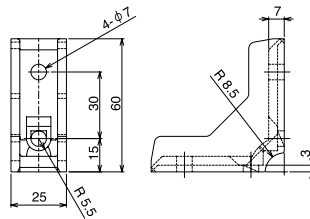

Model Number
ABLRD-30-6

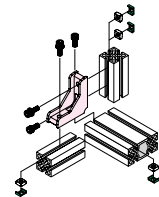

Example of use

Specifications

รุ่น Model Number	วัสดุ Material	ชุบผิว Surface treatment	มวล Mass [g]	Recommended Fastening Parts		
				รุ่นโบลท์ Bolt Model Number	รุ่น น็อต Nut Model Number	รุ่น แผ่นรองน็อต Nut Holder Model Number
ABLRD-30-6	ADC-12	Baking finish	61.5	CSW-06-18 (2 pieces) / CS-06-12 (2 pieces)	NSM-06-6 (4 pieces)	NH-06-GR (4 pieces)

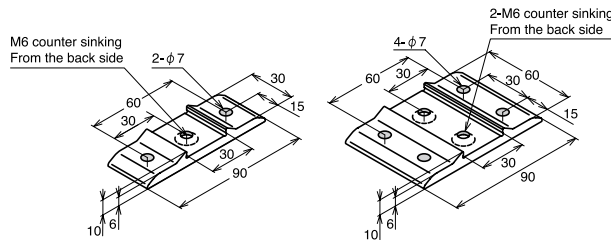

Model Number
ABJF-3030-6

Model Number
ABJF-3060-6

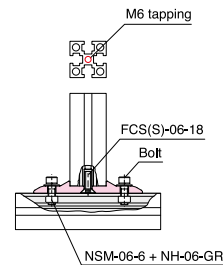

Example of use

Specifications

รุ่น Model Number	วัสดุ Material	ชุบผิว Surface treatment	มวล Mass [g]	Recommended Fastening Parts		
				รุ่นโบลท์ Bolt Model Number	รุ่น น็อต Nut Model Number	รุ่น แผ่นรองน็อต Nut Holder Model Number
ABJF-3030-6	A6N01S-T5	Anodize	41	CSW-06-18 (2 pieces) / FCS-06-18 (1 piece)	NSM-06-6 (2 pieces)	NH-06-GR (2 pieces)
ABJF-3060-6			82	CSW-06-18 (4 pieces) / FCS-06-18 (2 pieces)	NSM-06-6 (4 pieces)	NH-06-GR (4 pieces)

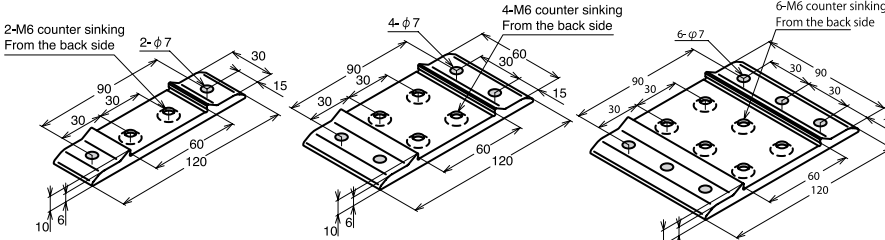

Model Number
ABJF-6030-6

Model Number
ABJF-6060-6

Model Number
ABJF-6090-6

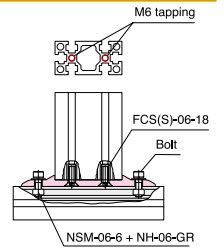

Example of use

Specifications

รุ่น Model Number	วัสดุ Material	ชุบผิว Surface treatment	มวล Mass [g]	Recommended Fastening Parts		
				รุ่นโบลท์ Bolt Model Number	รุ่น น็อต Nut Model Number	รุ่น แผ่นรองน็อต Nut Holder Model Number
ABJF-6030-6	A6N01S-T5	Anodize Clear coat	55	CSW-06-18 (2 pieces) / FCS-06-18 (2 pieces)	NSM-06-6 (2 pieces)	NH-06-GR (2 pieces)
ABJF-6060-6			110	CSW-06-18 (4 pieces) / FCS-06-18 (4 pieces)	NSM-06-6 (4 pieces)	NH-06-GR (4 pieces)
ABJF-6090-6			165	CSW-06-18 (6 pieces) / FCS-06-18 (6 pieces)	NSM-06-6 (6 pieces)	NH-06-GR (6 pieces)

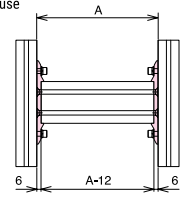

Bracket M6 series

Aluminium Frame

Bracket

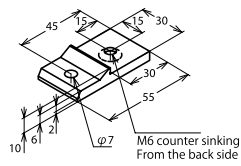
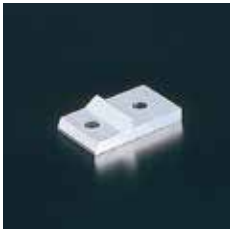

Model Number
ABJP-3030-6

Specifications

รุ่น Model Number	วัสดุ Material	ผิว Surface treatment	มวล Mass [g]	Recommended Fastening Parts		
				รุ่น Bolt Model Number	รุ่น Nut Model Number	รุ่น Nut Holder Model Number
ABJP-3030-6	A6063S-T5 / A6N01S-T5	Anodize Clear coat	25	CSW-06-18 (1 piece) / FCS-06-18 (1 piece)	NSM-06-6 (1 piece)	NH-06-GR (1 piece)

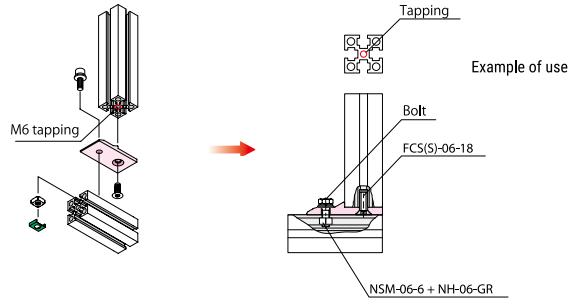

Accessory

Bolts & Nuts

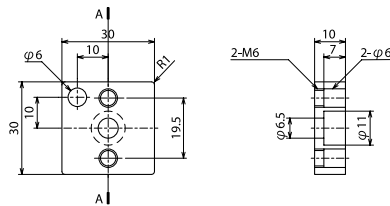

Model Number
AE-3030-6

Specifications

รุ่น Model Number	วัสดุ Material	ผิว Surface treatment	มวล Mass [g]
AE-3030-6	A6063S-T5 / A6N01S-T5	Anodize treatment Clear coat	23

Recommended Fastening Parts		
รุ่น Bolt Model Number	รุ่น Nut Model Number	รุ่น Nut Holder Model Number
CS-06-12 (1 piece) ECCS-06-19 (2 pieces)	NSM-06-6 (2 pieces)	NH-06-GR (2 pieces)

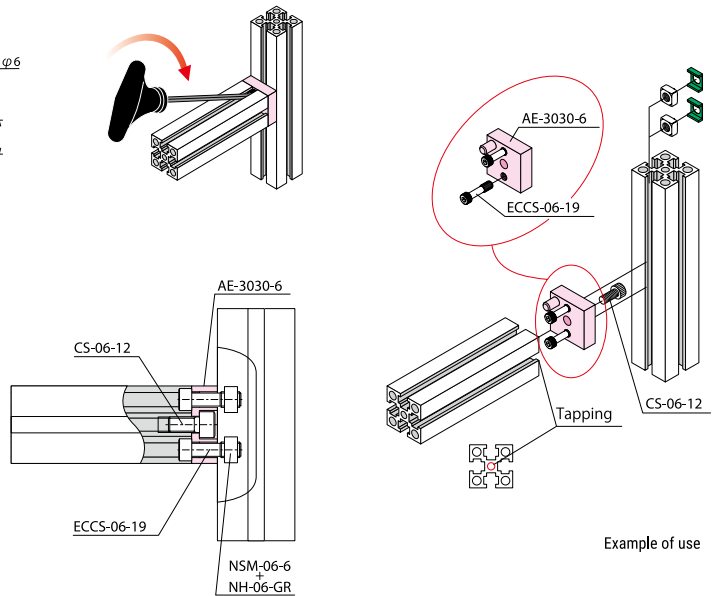

Rail Frame

Appendix

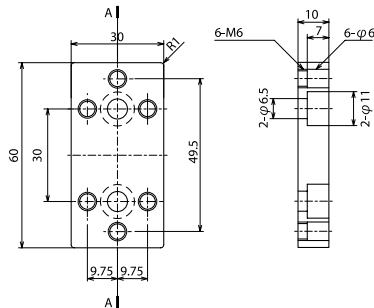

Model Number
AE-3060-6

Specifications

รุ่น Model Number	วัสดุ Material	ผิว Surface treatment	มวล Mass [g]
AE-3060-6	A6063S-T5 / A6N01S-T5	Anodize treatment Clear coat	40

Recommended Fastening Parts		
รุ่น Bolt Model Number	รุ่น Nut Model Number	รุ่น Nut Holder Model Number
CS-06-12 (2 pieces) ECCS-06-19 (4 pieces)	NSM-06-6 (4 pieces)	NH-06-GR (4 pieces)

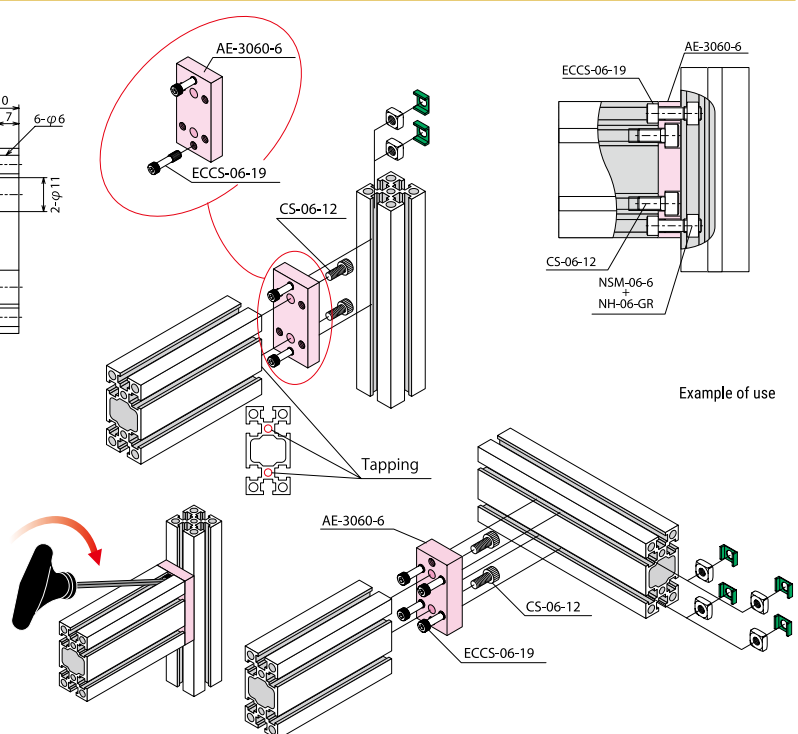

Threaded fastener

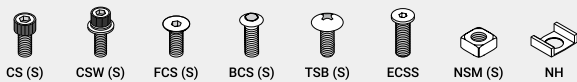



Model Number
AEC-3030-6

Specifications

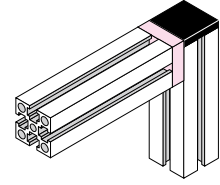
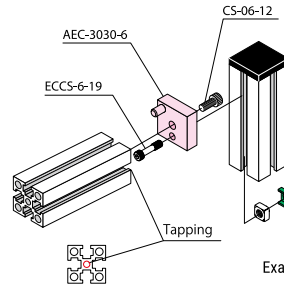
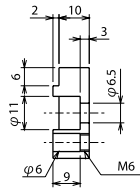
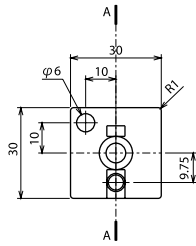

Example of use

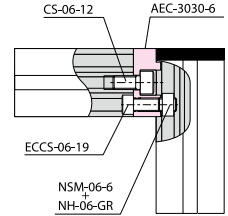

รุ่น Model Number	วัสดุ Material	ผิว Surface treatment	มวล Mass [g]	Recommended Fastening Parts		
				รุ่น Bolt Model Number	รุ่น Nut Model Number	รุ่น Nut Holder Model Number
AEC-3030-6	A6063S-T5 / A6N01S-T5	Anodize treatment Clear coat	37	CS-06-12 ECCS-06-19	NSM-06-6	NH-06-GR



Model Number
ABC-3030-6

Specifications

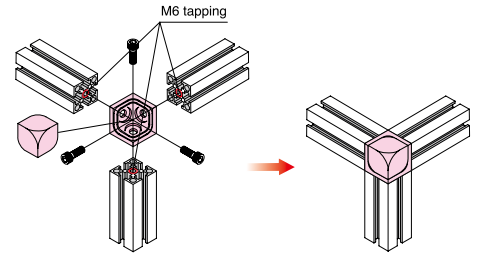
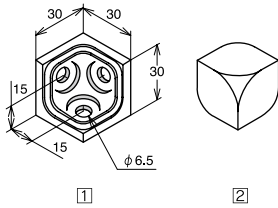

Example of use

รุ่น Model Number	วัสดุ Material	ผิว Surface treatment	มวล Mass [g]	Recommended Fastening Parts
				รุ่น Bolt Model Number
ABC-3030-6	① ADC-12 ② PA ③ PA	Baking finish	48	CS-06-12 (3 pieces)



Model Number
PMC-06-6

Specifications

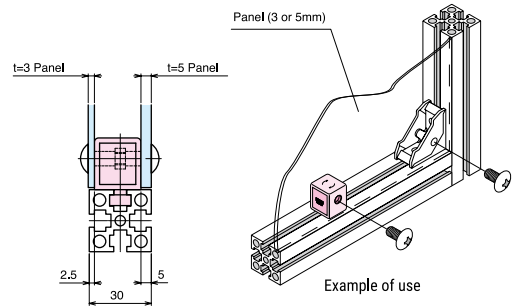
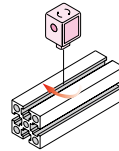
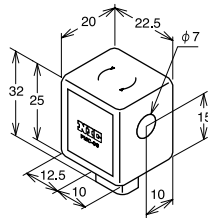

Example of use

รุ่น Model Number	วัสดุ Material	มวล Mass [g]	Recommended Fastening Parts
			รุ่น Bolt Model Number
PMC-06-6	POM / Nut: SUS XM7 (Equivalent)	13	TSB-06-25 (1 piece)



Model Number
ABT-4530-6

Specifications

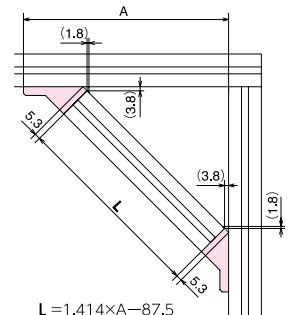
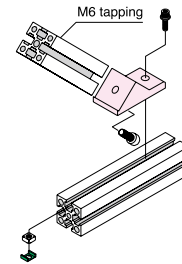
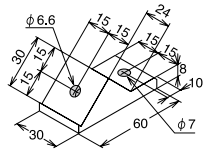

Example of use

รุ่น Model Number	วัสดุ Material	ผิว Surface treatment	มวล Mass [g]	Recommended Fastening Parts		
				รุ่น Bolt Model Number	รุ่น Nut Model Number	รุ่น Nut Holder Model Number
ABT-4530-6	A6063S-T5 / A6N01S-T5	Anodize	55	CSW-06-20 (1 piece) / CS-06-18 (1 piece)	NSM-06-6 (1 piece)	NH-06-GR (1 piece)

Bracket M6 series

Aluminium Frame

Bracket

Accessory

Bolts & Nuts

Rail Frame

Appendix

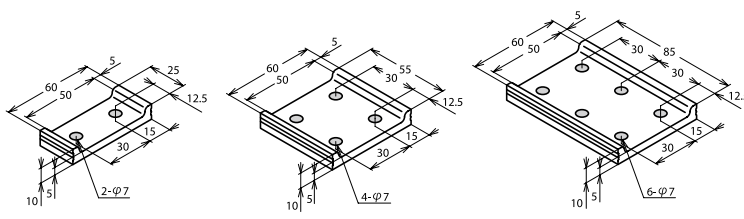

Model Number
ABSP-6025-6

Model Number
ABSP-6055-6

Model Number
ABSP-6085-6

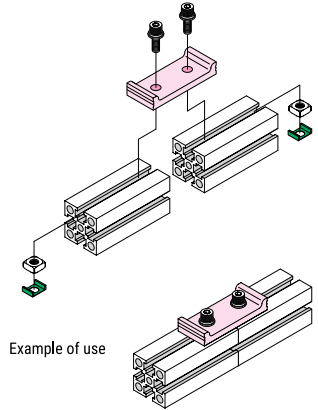

Example of use

Specifications

รุ่น Model Number	วัสดุ Material	ชุบผิว Surface treatment	มวล Mass [g]	Recommended Fastening Parts		
				รุ่นโบลท์ Bolt Model Number	รุ่น น็อต Nut Model Number	รุ่น แหนรองน็อต Nut Holder Model Number
ABSP-6025-6	A6N01S-T5	Anodize Clear coat	22	CSW-06-15 (2 pieces)	NSM-06-6 (2 pieces)	NH-06-GR (2 pieces)
ABSP-6055-6			48	CSW-06-15 (4 pieces)	NSM-06-6 (4 pieces)	NH-06-GR (4 pieces)
ABSP-6085-6			75	CSW-06-15 (6 pieces)	NSM-06-6 (6 pieces)	NH-06-GR (6 pieces)

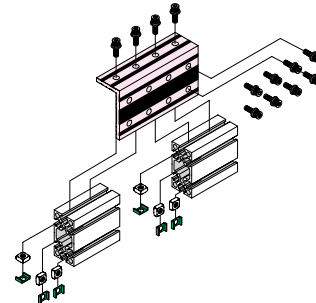
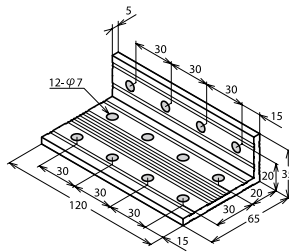

NSM-06-6 + NH-06-GR

Example of use

Model Number
ABJL-60120-6

Specifications

รุ่น Model Number	วัสดุ Material	ชุบผิว Surface treatment	มวล Mass [g]	Recommended Fastening Parts		
				รุ่นโบลท์ Bolt Model Number	รุ่น น็อต Nut Model Number	รุ่น แหนรองน็อต Nut Holder Model Number
ABJL-60120-6	A6N01S-T5	Anodize Clear coat	133	CSW-06-15 (12 pieces)	NSM-06-6 (12 pieces)	NH-06-GR (12 pieces)

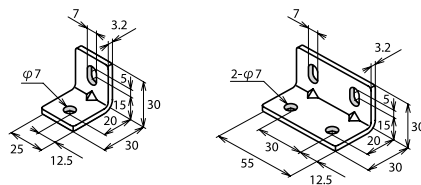

Model Number
BLSM-3025-6

Model Number
BLSM-3055-6

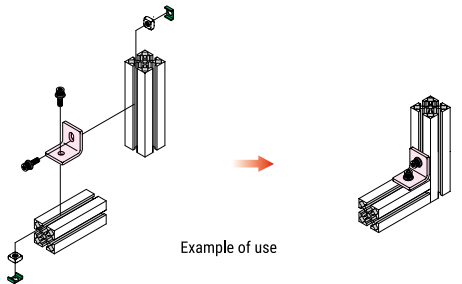

Example of use

Specifications

รุ่น Model Number	วัสดุ Material	ชุบผิว Surface treatment	มวล Mass [g]	Recommended Fastening Parts		
				รุ่นโบลท์ Bolt Model Number	รุ่น น็อต Nut Model Number	รุ่น แหนรองน็อต Nut Holder Model Number
BLSM-3025-6	SPHC	Trivalent chromate	30	CSW-06-15 (2 pieces)	NSM-06-6 (2 pieces)	NH-06-GR (2 pieces)
BLSM-3055-6			68	CSW-06-15 (4 pieces)	NSM-06-6 (4 pieces)	NH-06-GR (4 pieces)

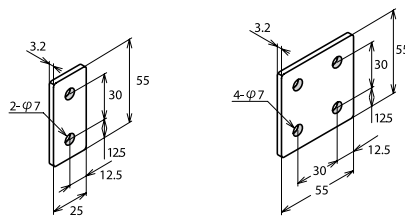

Model Number
BPSM-2555-6

Model Number
BPSM-5555-6

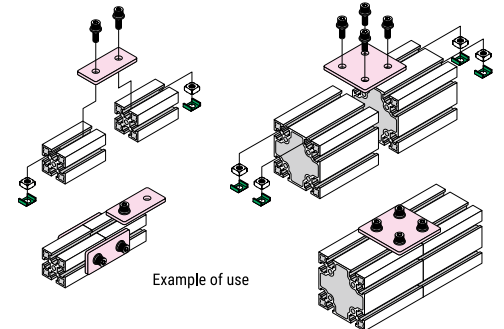

Example of use

Specifications

รุ่น Model Number	วัสดุ Material	ชุบผิว Surface treatment	มวล Mass [g]	Recommended Fastening Parts		
				รุ่นโบลท์ Bolt Model Number	รุ่น น็อต Nut Model Number	รุ่น แหนรองน็อต Nut Holder Model Number
BPSM-2555-6	SPHC	Trivalent chromate	32	CSW-06-15 (2 pieces)	NSM-06-6 (2 pieces)	NH-06-GR (2 pieces)
BPSM-5555-6			69	CSW-06-15 (4 pieces)	NSM-06-6 (4 pieces)	NH-06-GR (4 pieces)

Threaded fastener

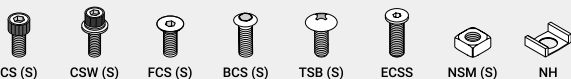



Model Number
BPLM-8080-6

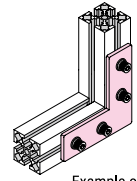
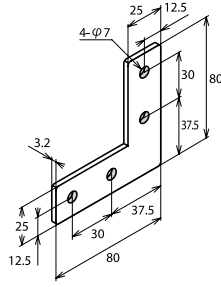

Example of use

Specifications

รุ่น Model Number	วัสดุ Material	ผิว Surface treatment	มวล Mass [g]	Recommended Fastening Parts		
				รุ่น Bolt Model Number	รุ่น Nut Model Number	รุ่น Nut Holder Model Number
BPLM-8080-6	SPHC	Trivalent chromate	79	CSW-06-15 (4 pieces)	NSM-06-6 (4 pieces)	NH-06-GR (4 pieces)



Model Number
BPTM-6085-6

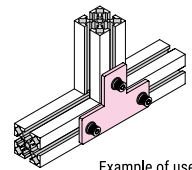
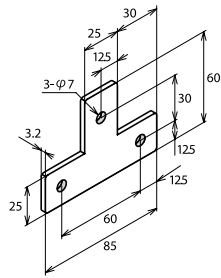

Example of use

Specifications

รุ่น Model Number	วัสดุ Material	ผิว Surface treatment	มวล Mass [g]	Recommended Fastening Parts		
				รุ่น Bolt Model Number	รุ่น Nut Model Number	รุ่น Nut Holder Model Number
BPTM-6085-6	SPHC	Trivalent chromate	69	CSW-06-15 (3 pieces)	NSM-06-6 (3 pieces)	NH-06-GR (3 pieces)



Model Number
EZPS-06

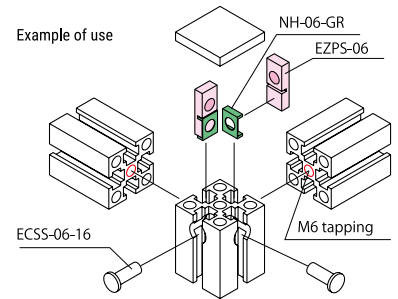
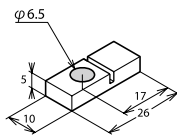

Example of use

Specifications

รุ่น Model Number	วัสดุ Material	ผิว Surface treatment	มวล Mass [g]	Recommended Fastening Parts	
				รุ่น Bolt Model Number	รุ่น Nut Holder Model Number
EZPS-06	SUS304	—	8.3	ECSS-06-16 (1 piece)	NH-06-GR (1 piece)

Bracket M8 series

Aluminium Frame

Bracket



Model Number
ABLD-40-8-N(-T)

Specifications

Model Number	Material	Surface treatment	Mass [g]	Bolt Model Number	Recommended Fastening Parts	Nut Model Number	Nut Holder Model Number
ABLD-40-8-N	ADC-12	—	68	CSW-08-20 (2 pieces)	Recommended Fastening Parts		
ABLD-40-8-N-T					NSM-08-8 (2 pieces)	NH-08-GR (2 pieces)	

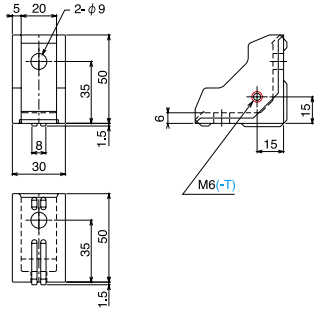

(-T) at the end of Model Number means one side M6 tapping.

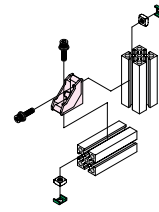

Example of use

Accessory

Bolts & Nuts



Model Number
ABLD-80-8-N(-T)

Specifications

Model Number	Material	Surface treatment	Mass [g]	Bolt Model Number	Recommended Fastening Parts	Nut Model Number	Nut Holder Model Number
ABLD-80-8-N	ADC-12	—	136	CSW-08-20 (4 pieces)	Recommended Fastening Parts		
ABLD-80-8-N-T					NSM-08-8 (4 pieces)	NH-08-GR (4 pieces)	

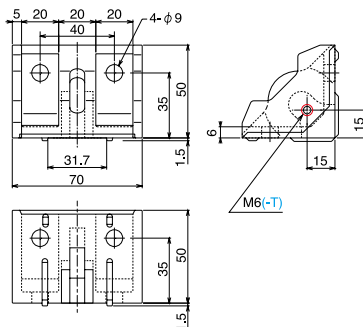

(-T) at the end of Model Number means one side M6 tapping.

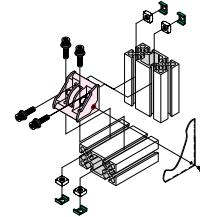

Example of use

Rail Frame

Appendix

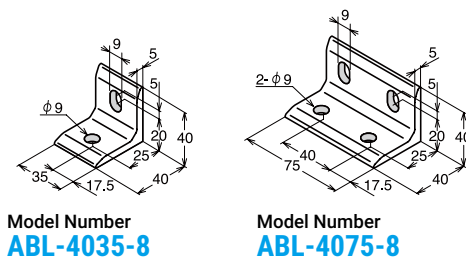

Model Number
ABL-4035-8

Model Number
ABL-4075-8

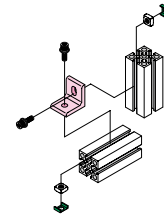

Example of use

Specifications

Model Number	Material	Surface treatment	Mass [g]	Bolt Model Number	Recommended Fastening Parts	Nut Model Number	Nut Holder Model Number
ABL-4035-8	A6N01S-T5	Anodize	32	CSW-08-20 (2 pieces)	Recommended Fastening Parts		
ABL-4075-8			69	CSW-08-20 (4 pieces)	NSM-08-8 (2 pieces)	NH-08-GR (2 pieces)	
					NSM-08-8 (4 pieces)	NH-08-GR (4 pieces)	

(-T) at the end of Model Number means one side M6 tapping.

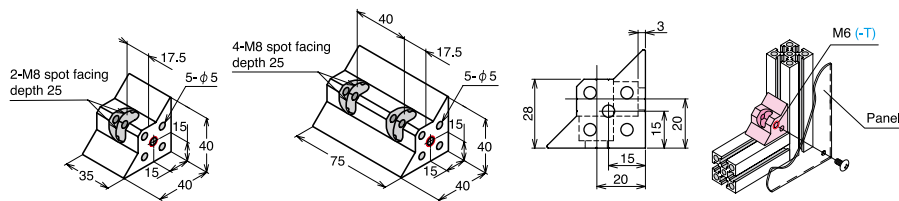

Model Number
ABLB-4035-8(-T)

Model Number
ABLB-4075-8(-T)

Example of use

Specifications

Model Number	Material	Surface treatment	Mass [g]	Bolt Model Number	Recommended Fastening Parts	Nut Model Number	Nut Holder Model Number
ABLB-4035-8(-T)	A6063S-T5 / A6N01S-T5	Anodize	32	CSW-08-20 (2 pieces)	Recommended Fastening Parts		
ABLB-4075-8(-T)			69	CSW-08-20 (4 pieces)	NSM-08-8 (2 pieces)	NH-08-GR (2 pieces)	
					NSM-08-8 (4 pieces)	NH-08-GR (4 pieces)	

Threaded fastener

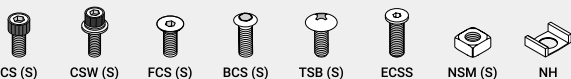

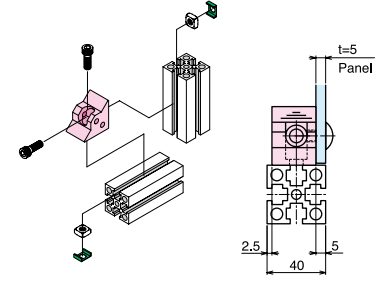
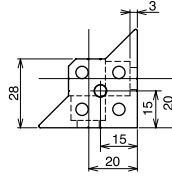
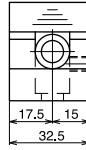
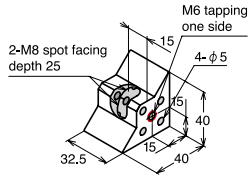

Model Number
ABLB-4035-8-C5

Specifications

รุ่น Model Number	วัสดุ Material	ชุบผิว Surface treatment	มวล Mass [g]	Recommended Fastening Parts		
				รุ่นโบลท์ Bolt Model Number	รุ่น น็อต Nut Model Number	รุ่น แหนรองน็อต Nut Holder Model Number
ABLB-4035-8-C5	A6063S-T5 / A6N01S-T5	Anodize	57.5	CSW-08-15 (2 pieces)	NSM-08-8 (2 pieces)	NH-08-GR (2 pieces)

Example of use

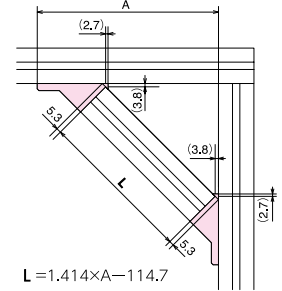
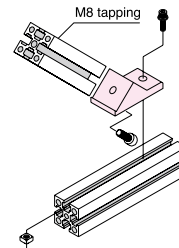
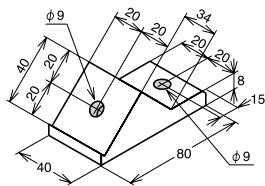

Model Number
ABT-4540-8

Specifications

รุ่น Model Number	วัสดุ Material	ชุบผิว Surface treatment	มวล Mass [g]	Recommended Fastening Parts		
				รุ่นโบลท์ Bolt Model Number	รุ่น น็อต Nut Model Number	รุ่น แหนรองน็อต Nut Holder Model Number
ABT-4540-8	A6063S-T5 / A6N01S-T5	Anodize	110	CSW-08-25 (1 piece) / CS-08-25 (1 piece)	NSM-08-8 (1 piece)	NH-08-GR (1 piece)

Example of use

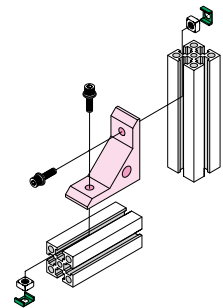
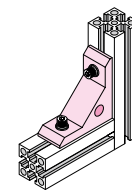
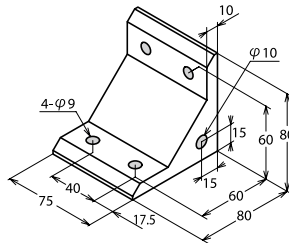
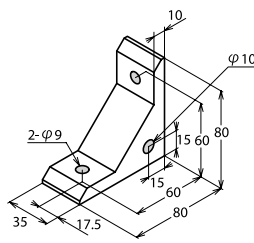

Model Number
ABLH-8035-8

Model Number
ABLH-8075-8

Specifications

รุ่น Model Number	วัสดุ Material	ชุบผิว Surface treatment	มวล Mass [g]	Recommended Fastening Parts		
				รุ่นโบลท์ Bolt Model Number	รุ่น น็อต Nut Model Number	รุ่น แหนรองน็อต Nut Holder Model Number
ABLH-8035-8	A6063S-T5 / A6N01S-T5	Anodize	192	CSW-08-25 (2 pieces)	NSM-08-8 (2 pieces)	NH-08-GR (2 pieces)
ABLH-8075-8			407	CSW-08-25 (4 pieces)	NSM-08-8 (4 pieces)	NH-08-GR (4 pieces)

Example of use

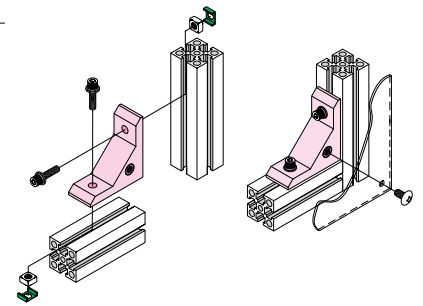
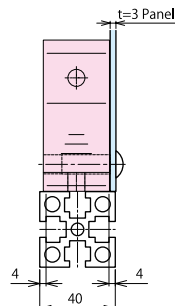
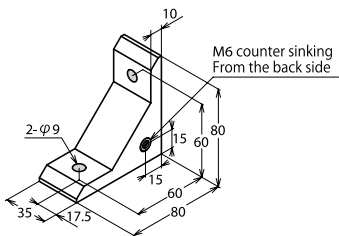

Model Number
ABCH-8035-8

Specifications

รุ่น Model Number	วัสดุ Material	ชุบผิว Surface treatment	มวล Mass [g]	Recommended Fastening Parts		
				รุ่นโบลท์ Bolt Model Number	รุ่น น็อต Nut Model Number	รุ่น แหนรองน็อต Nut Holder Model Number
ABCH-8035-8	A6063S-T5 / A6N01S-T5 Bush: SUS303	Anodize	192	CSW-08-25 (2 pieces)	NSM-08-8 (2 pieces)	NH-08-GR (2 pieces)

Bracket M8 series

Aluminium Frame

Bracket

Accessory

Bolts & Nuts

Rail Frame

Appendix

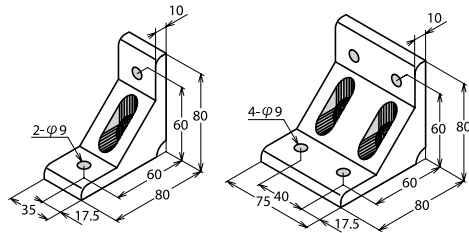

Model Number
ABLR-8035-8

Model Number
ABLR-8075-8

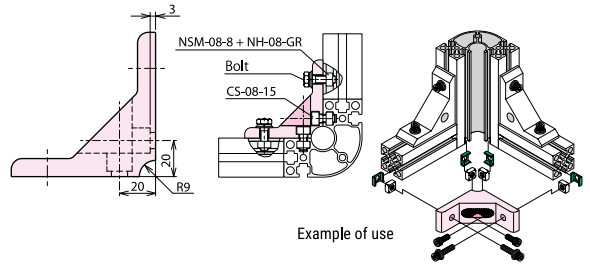

Example of use

Specifications

รุ่น Model Number	วัสดุ Material	ผิว Surface treatment	มวล Mass [g]	Recommended Fastening Parts		
				รุ่น Bolt Model Number	รุ่น Nut Model Number	รุ่น Nut Holder Model Number
ABLR-8035-8	A6063S-T5 / A6N01S-T5	Anodize	167	CSW-08-25 (2 pieces) / CS-08-15 (2 pieces)	NSM-08-8 (4 pieces)	NH-08-GR (4 pieces)
ABLR-8075-8	A6063S-T5 / A6N01S-T5	Anodize	362	CSW-08-25 (4 pieces) / CS-08-15 (4 pieces)	NSM-08-8 (8 pieces)	NH-08-GR (8 pieces)

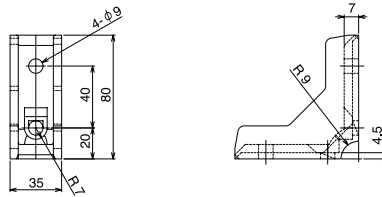

Model Number
ABLRD-40-8

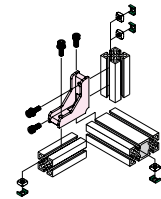

Example of use

Specifications

รุ่น Model Number	วัสดุ Material	ผิว Surface treatment	มวล Mass [g]	Recommended Fastening Parts		
				รุ่น Bolt Model Number	รุ่น Nut Model Number	รุ่น Nut Holder Model Number
ABLRD-40-8	ADC-12	Baking finish	130	CSW-08-20 (2 pieces) / FCS-08-15 (2 pieces)	NSM-08-8 (4 pieces)	NH-08-GR (4 pieces)

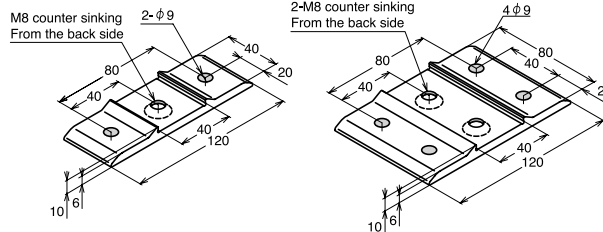

Model Number
ABJF-4040-8

Model Number
ABJF-4080-8

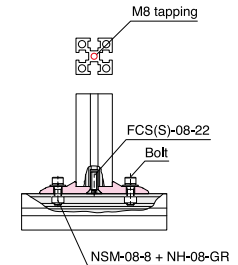

Example of use

Specifications

รุ่น Model Number	วัสดุ Material	ผิว Surface treatment	มวล Mass [g]	Recommended Fastening Parts		
				รุ่น Bolt Model Number	รุ่น Nut Model Number	รุ่น Nut Holder Model Number
ABJF-4040-8	A6N01S-T5	Anodize	74	CSW-08-20 (2 pieces) / FCS-08-22 (1 piece)	NSM-08-8 (2 pieces)	NH-08-GR (2 pieces)
ABJF-4080-8	A6N01S-T5	Clear coat	148	CSW-08-20 (4 pieces) / FCS-08-22 (2 pieces)	NSM-08-8 (4 pieces)	NH-08-GR (4 pieces)

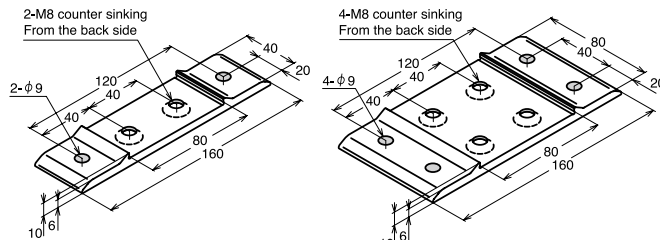

Model Number
ABJF-8040-8

Model Number
ABJF-8080-8

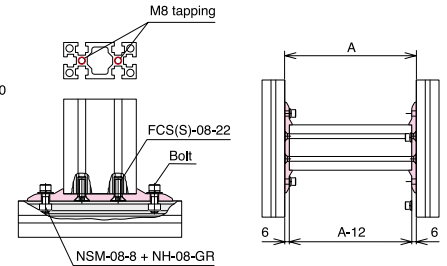

Example of use

Specifications

รุ่น Model Number	วัสดุ Material	ผิว Surface treatment	มวล Mass [g]	Recommended Fastening Parts		
				รุ่น Bolt Model Number	รุ่น Nut Model Number	รุ่น Nut Holder Model Number
ABJF-8040-8	A6N01S-T5	Anodize	95	CSW-08-20 (2 pieces) / FCS-08-22 (1 piece)	NSM-08-8 (2 pieces)	NH-08-GR (2 pieces)
ABJF-8080-8	A6N01S-T5	Clear coat	190	CSW-08-20 (4 pieces) / FCS-08-22 (2 pieces)	NSM-08-8 (4 pieces)	NH-08-GR (4 pieces)

Threaded fastener

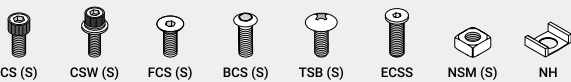

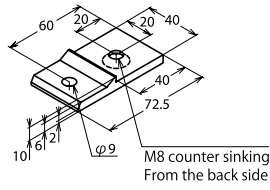

Example of use

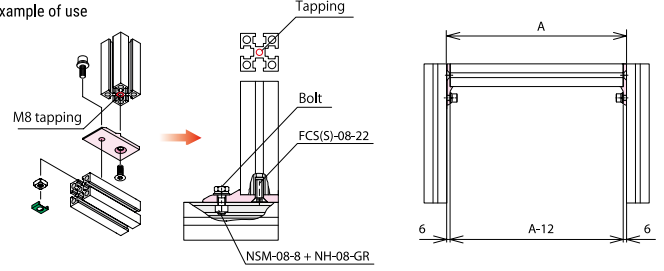

Model Number
ABJP-4040-8

Specifications

รุ่น Model Number	วัสดุ Material	ผิว Surface treatment	มวล Mass [g]	Recommended Fastening Parts		
				รุ่น Bolt Model Number	รุ่น Nut Model Number	รุ่น Nut Holder Model Number
ABJP-4040-8	A6N01S-T5	Anodize Clear coat	44	CSW-08-20 (1 piece) / FCS-08-22 (1 piece)	NSM-08-8 (1 piece)	NH-08-GR (1 piece)

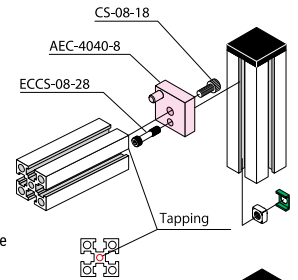
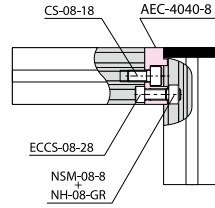
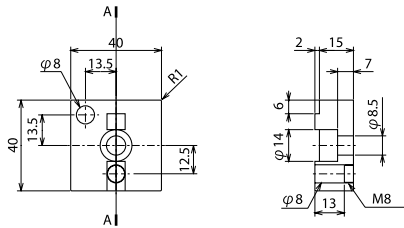

Model Number
AEC-4040-8

Specifications

รุ่น Model Number	วัสดุ Material	ผิว Surface treatment	มวล Mass [g]	Recommended Fastening Parts	
				รุ่น Nut Model Number	รุ่น Nut Holder Model Number
AEC-4040-8	A6063S-T5 / A6N01S-T5	Anodize Clear coat	64	NSM-08-8 (1 piece)	NH-08-GR (1 piece)

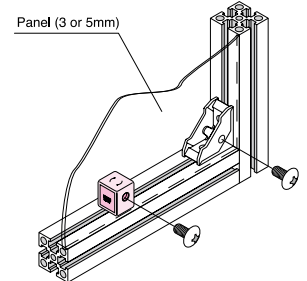
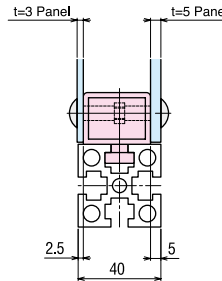
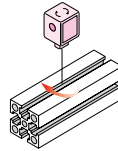
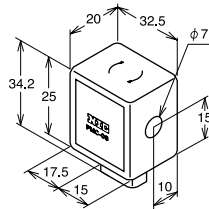
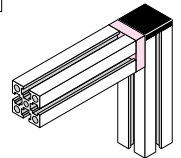

Model Number
PMC-08-6

Specifications

รุ่น Model Number	วัสดุ Material	มวล Mass [g]	Recommended Fastening Parts
			รุ่น Bolt Model Number
PMC-08-6	POM / Nut: SUS XW7 (Equivalent)	17	TSB-06-25 (1 piece)

Example of use

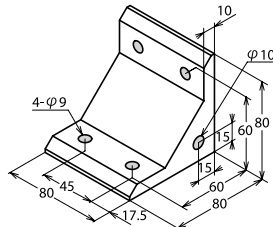
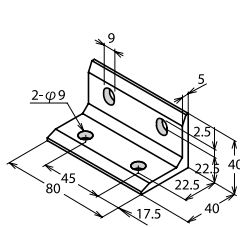

Model Number
ABL-4080-8

Model Number
ABLH-8080-8

Specifications

รุ่น Model Number	วัสดุ Material	ผิว Surface treatment	มวล Mass [g]	Recommended Fastening Parts		
				รุ่น Bolt Model Number	รุ่น Nut Model Number	รุ่น Nut Holder Model Number
ABL-4080-8	A6063S-T5 / A6N01S-T5	Anodize	74	CSW-08-20 (4 pieces)	NSM-08-8 (4 pieces)	NH-08-GR (4 pieces)
ABLH-8080-8			148	CSW-08-25 (4 pieces)	NSM-08-8 (4 pieces)	NH-08-GR (4 pieces)

Bracket M8 series

Aluminium Frame

Bracket

Accessory

Bolts & Nuts

Rail Frame

Appendix

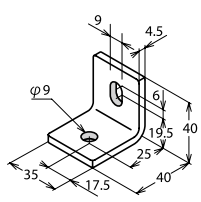

Model Number
BLSM-4035-8

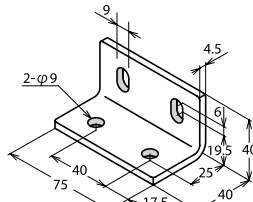

Model Number
BLSM-4075-8

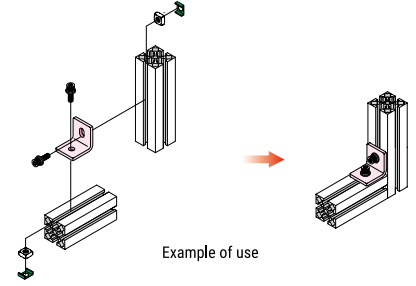

Example of use

Specifications

Model Number	Material	Surface treatment	Mass [g]	Recommended Fastening Parts		
				Bolt Model Number	Nut Model Number	Nut Holder Model Number
BLSM-4035-8	SPHC	Trivalent chromate	80	CSW-08-20 (2 pieces)	NSM-08-8 (2 pieces)	NH-08-GR (2 pieces)
BLSM-4075-8			170	CSW-08-20 (4 pieces)	NSM-08-8 (4 pieces)	NH-08-GR (4 pieces)

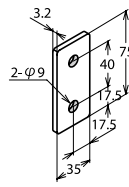

Model Number
BPSM-3575-8

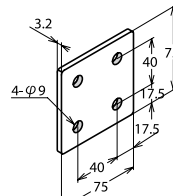

Model Number
BPSM-7575-8

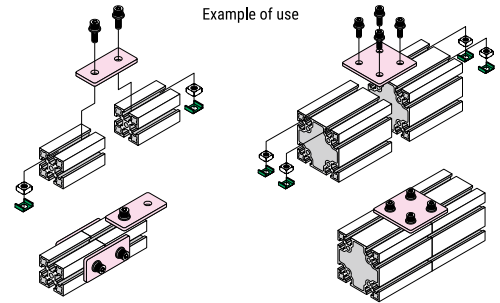

Example of use

Specifications

Model Number	Material	Surface treatment	Mass [g]	Recommended Fastening Parts		
				Bolt Model Number	Nut Model Number	Nut Holder Model Number
BPSM-3575-8	SPHC	Trivalent chromate	60	CSW-08-20 (2 pieces)	NSM-08-8 (2 pieces)	NH-08-GR (2 pieces)
BPSM-7575-8			133	CSW-08-20 (4 pieces)	NSM-08-8 (4 pieces)	NH-08-GR (4 pieces)

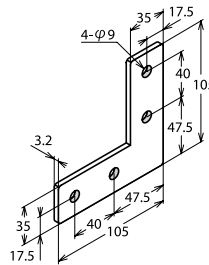

Model Number
BPLM-105105-8

Example of use

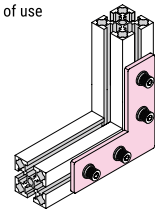

Specifications

Model Number	Material	Surface treatment	Mass [g]	Recommended Fastening Parts		
				Bolt Model Number	Nut Model Number	Nut Holder Model Number
BPLM-105105-8	SPHC	Trivalent chromate	145	CSW-08-20 (4 pieces)	NSM-08-8 (2 pieces)	NH-08-GR (2 pieces)

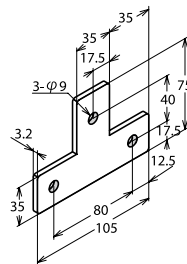

Model Number
BPTM-75106-8

Example of use

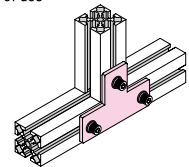

Specifications

Model Number	Material	Surface treatment	Mass [g]	Recommended Fastening Parts		
				Bolt Model Number	Nut Model Number	Nut Holder Model Number
BPTM-75106-8	SPHC	Trivalent chromate	120	CSW-08-20 (3 pieces)	NSM-08-8 (3 pieces)	NH-08-GR (3 pieces)

Threaded fastener

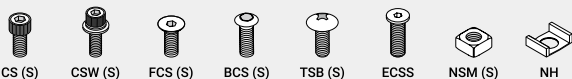



Model Number
EZPS-08

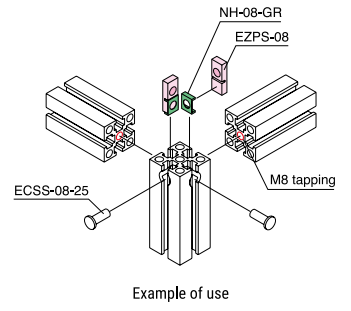
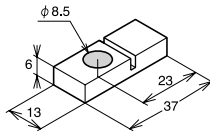

Specifications

Model Number	Material	Surface treatment	Mass [g]	Recommended Fastening Parts	
				Bolt Model Number	Nut Holder Model Number
EZPS-08	SUS304	—	18.5	ECSS-08-25 (1 piece)	NH-08-GR (1 piece)

Accessory — END CAP

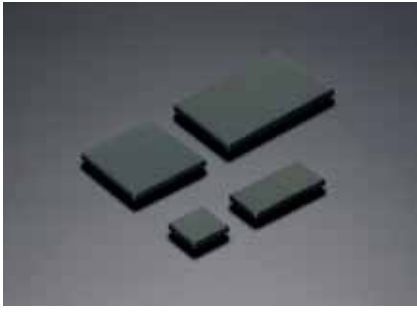

Common Specifications

วัสดุ Material	ABS
สี Color	ดำ Black เทา Gray (-GY model)

M4

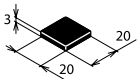

Model Number
ECP-2020-4
ECP-2020-4-GY

Mass [g]	1.1
----------	-----

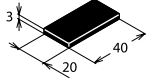

Model Number
ECP-2040-4
ECP-2040-4-GY

Mass [g]	2.0
----------	-----

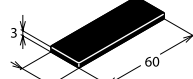

Model Number
ECP-2060-4

Mass [g]	3.5
----------	-----

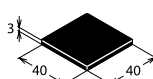

Model Number
ECP-4040-4
ECP-4040-4-GY

Mass [g]	5.1
----------	-----

Attachment configuration

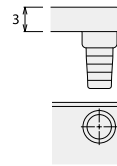

M6

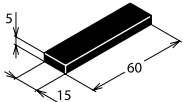

Model Number
ECP-1560-6

Mass [g]	5.0
Attachment configuration	A-type

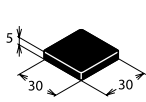

Model Number
ECP-3030-6
ECP-3030-6-GY

Mass [g]	3.5
Attachment configuration	B-type

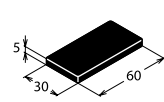

Model Number
ECP-3060-6
ECP-3060-6-GY

Mass [g]	5.5
Attachment configuration	B-type

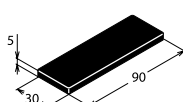

Model Number
ECP-3090-6
ECP-3090-6-GY

Mass [g]	7.0
Attachment configuration	C-type

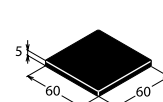

Model Number
ECP-6060-6
ECP-6060-6-GY

Mass [g]	10.0
Attachment configuration	B-type

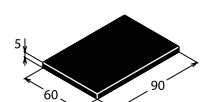

Model Number
ECP-6090-6
ECP-6090-6-GY

Mass [g]	12.0
Attachment configuration	C-type

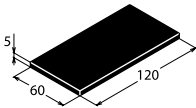

Model Number
ECP-60120-6

Mass [g]	20.0
Attachment configuration	D-type

Attachment configuration

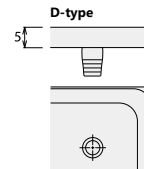
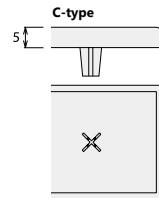
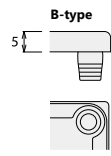
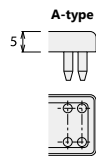

M8

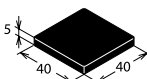

Model Number
ECP-4040-8
ECP-4040-8-GY

Mass [g]	5.0
Attachment configuration	A-type

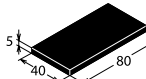

Model Number
ECP-4080-8
ECP-4080-8-GY

Mass [g]	9.0
Attachment configuration	A-type

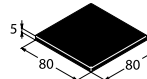

Model Number
ECP-8080-8
ECP-8080-8-GY

Mass [g]	18.0
Attachment configuration	A-type

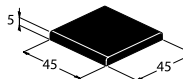

Model Number
ECP-4545-8

Mass [g]	6.3
Attachment configuration	B-type



Model Number
ECP-4590-8

Mass [g]	10.6
Attachment configuration	C-type

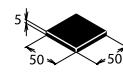

Model Number
ECP-5050-8

Mass [g]	7.2
Attachment configuration	D-type



Model Number
ECP-100100-10

Mass [g]	27.4
Attachment configuration	E-type

Attachment configuration

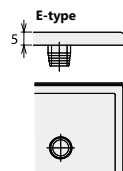
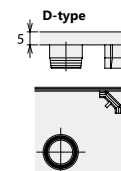
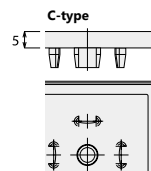
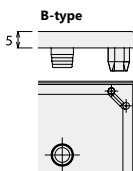
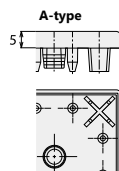

Accessory — HINGE



Common Specifications

วัสดุ Material	ADC-12
ผิวผิว Surface treatment	Acrylic coating
สี Color	Silver

M4

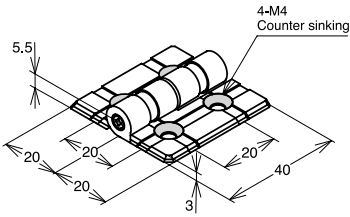

Model Number
AHS-4040-4-L-SL (Left opening)
AHS-4040-4-R-SL (right opening)
 This describes AHS-4040-4-L

Specifications

Mass [g]	18.8
Allowable load	100N (2 pieces)

Accessories (Model Number)

Bolt	FCS-04-09 (4 pieces)
------	----------------------

Recommended Fastening Parts (Model Number)

Nut	NSM-04-4 (4 pieces)
Nut Holder	NH-04-GR (4 pieces)

M6

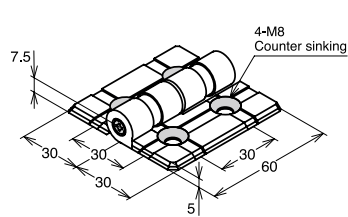

Model Number
AHS-6060-6-L-SL (Left opening)
AHS-6060-6-R-SL (right opening)
 This describes AHS-6060-6-L

Specifications

Mass [g]	52.0
Allowable load	150N (2 pieces)

Accessories (Model Number)

Bolt	FCS-06-14 (4 pieces)
------	----------------------

Recommended Fastening Parts (Model Number)

Nut	NSM-06-6 (4 pieces)
Nut Holder	NH-06-GR (4 pieces)

M8

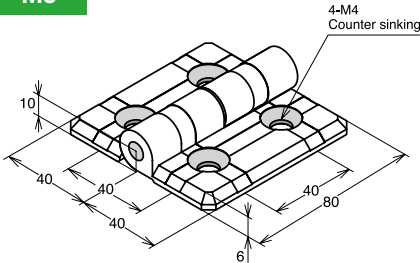

Model Number
AHS-8080-8-L-SL (Left opening)
AHS-8080-8-R-SL (right opening)
 This describes AHS-8080-8-L

Specifications

Mass [g]	120
Allowable load	150N (2 pieces)

Accessories (Model Number)

Bolt	FCS-08-18 (4 pieces)
------	----------------------

Recommended Fastening Parts (Model Number)

Nut	NSM-08-8 (4 pieces)
Nut Holder	NH-08-GR (4 pieces)

Example of use

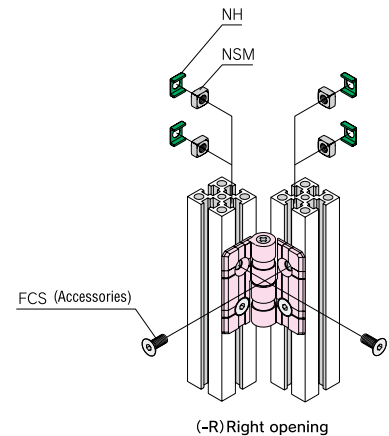
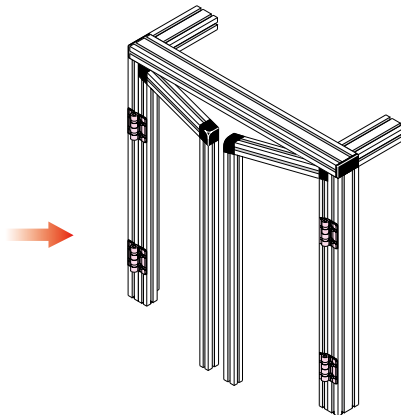
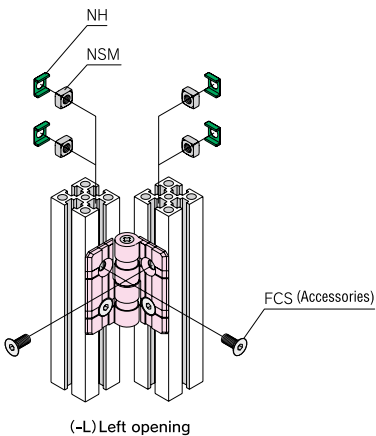

Threaded fastener

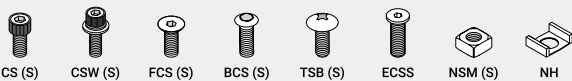

Accessory — HINGE

Aluminium Frame

Bracket

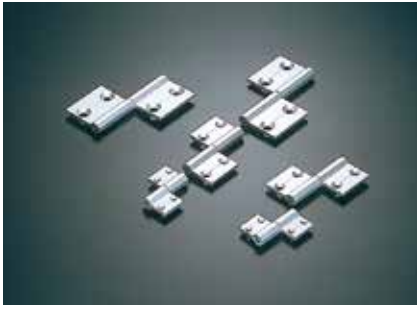

Specifications

วัสดุ Material	A6N01S-T5
ชั้นผิว Surface treatment	Anodize Clear coat
สี Color	Silver

Accessory

M6

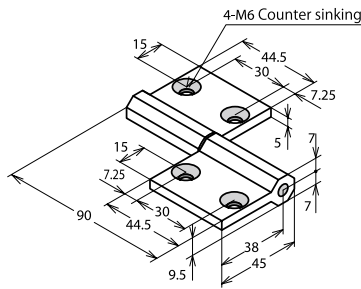

Specifications

Mass [g]	96.0
Allowable load	150N (2 pieces)

Accessories (Model Number)

Bolt	FCS-06-14 (4 pieces)
------	-------------------------

Recommended Fastening Parts (Model Number)

Nut	NSM-06-6 (4 pieces)
Nut Holder	NH-06-GR (4 pieces)

Model Number

AHC-6090-6-L-SL (Left opening)

AHC-6090-6-R-SL (right opening)

This describes AHC-6090-6-L

Bolts & Nuts

Rail Frame

Appendix

Example of use

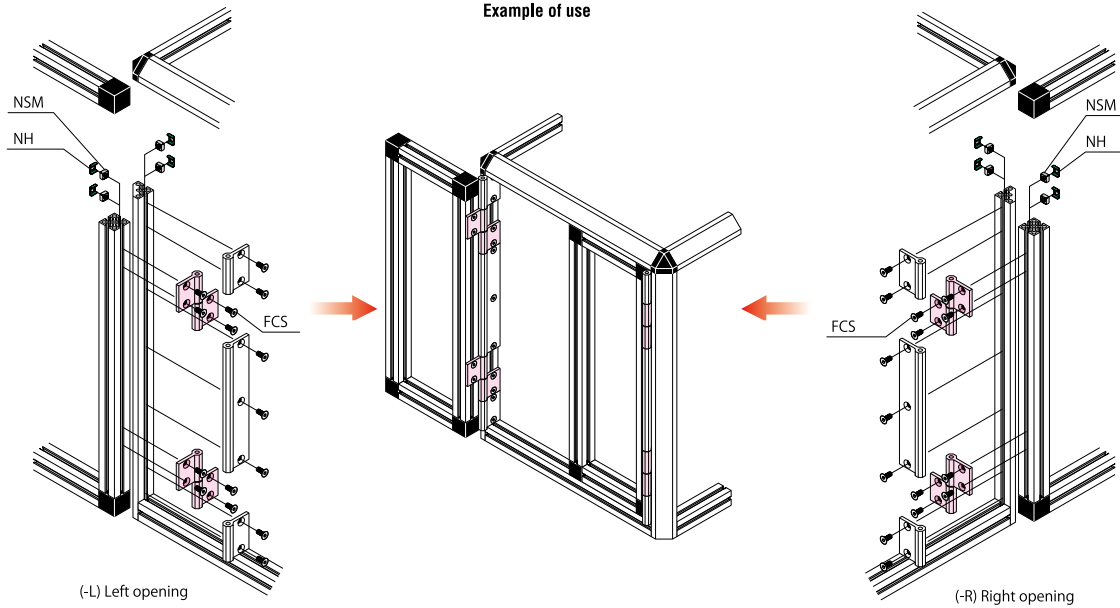

Threaded fastener

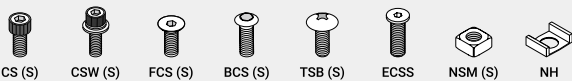



Common Specifications

วัสดุ Material	A6N01S-T5
ผิว Surface treatment	Anodize
สี Color	Silver

M4
M6

Model Number
AHS-46

Specifications

Mass [g]	49.5
Allowable load	100N (2 pieces)

Recommended Fastening Parts (Model Number)

Bolt	CSW-04-12 (2 pieces) CSW-06-15 (2 pieces)
Nut	NSM-04-4 (2 pieces) NSM-06-6 (2 pieces)
Nut Holder	NH-04-GR (2 pieces) NH-06-GR (2 pieces)

M4
M8

Model Number
AHS-48

Specifications

Mass [g]	51.0
Allowable load	100N (2 pieces)

Recommended Fastening Parts (Model Number)

Bolt	CSW-04-12 (2 pieces) CSW-08-20 (2 pieces)
Nut	NSM-04-4 (2 pieces) NSM-08-8 (2 pieces)
Nut Holder	NH-04-GR (2 pieces) NH-08-GR (2 pieces)

M6
M8

Model Number
AHS-68

Specifications

Mass [g]	75.2
Allowable load	150N (2 pieces)

Recommended Fastening Parts (Model Number)

Bolt	CSW-06-15 (2 pieces) CSW-08-20 (2 pieces)
Nut	NSM-06-6 (2 pieces) NSM-08-8 (2 pieces)
Nut Holder	NH-06-GR (2 pieces) NH-08-GR (2 pieces)

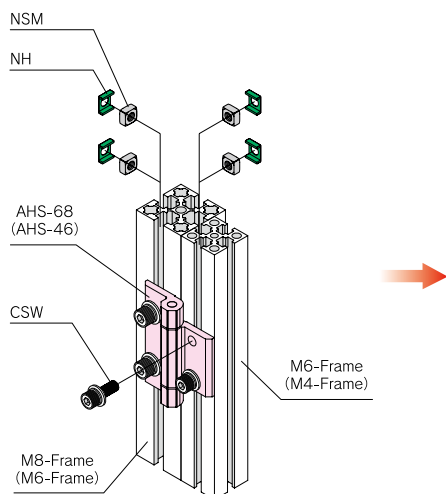

Example of use

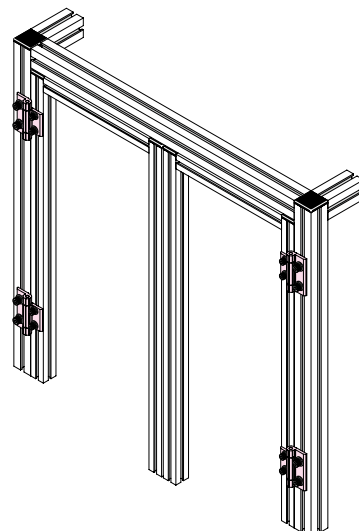

Accessory — HINGE

Aluminium Frame

Bracket



Common Specifications

วัสดุ Material	1 A6063S-T5 / A6N01S-T5 2 SU304 3 PA 4 POM
การผิว Surface treatment	Anodize
Allowable load	500N (2 pieces)
สี Color	Silver

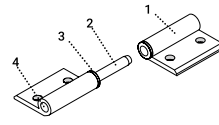

Upper part

Lower part

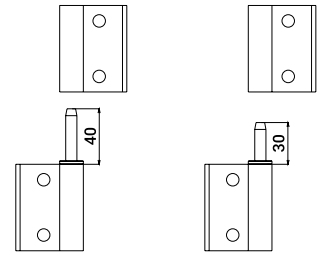

*One set as two connected parts.

Accessory

Bolts & Nuts

Rail Frame

M6

Specifications

Mass [g]	250.0 (1 pieces)
----------	------------------

Recommended Fastening Parts (Model Number)

Bolt	CSW-06-15 (8 pieces)
Nut	NSM-06-6 (8 pieces)
Nut Holder	NH-06-GR (8 pieces)

Model Number
AHH-60127-6-L (Left opening)
AHH-60127-6-R (right opening)

This describes AHH-60127-6-L

M8

Specifications

Mass [g]	281.0 (1 pieces)
----------	------------------

Recommended Fastening Parts (Model Number)

Bolt	CSW-08-20 (8 pieces)
Nut	NSM-08-8 (8 pieces)
Nut Holder	NH-08-GR (8 pieces)

Model Number
AHH-80127-8-L (Left opening)
AHH-80127-8-R (right opening)

This describes AHH-80127-8-L

Appendix

M6
M8

Specifications

Mass [g]	258.0 (1 pieces)
----------	------------------

Recommended Fastening Parts (Model Number)

Bolt	CSW-06-15 (4 pieces) CSW-08-20 (4 pieces)
Nut	NSM-06-6 (4 pieces) NSM-08-8 (4 pieces)
Nut Holder	NH-06-GR (4 pieces) NH-08-GR (4 pieces)

Model Number
AHH-70127-68-L (Left opening)
AHH-70127-68-R (right opening)

This describes AHH-70127-68-L

Example of use

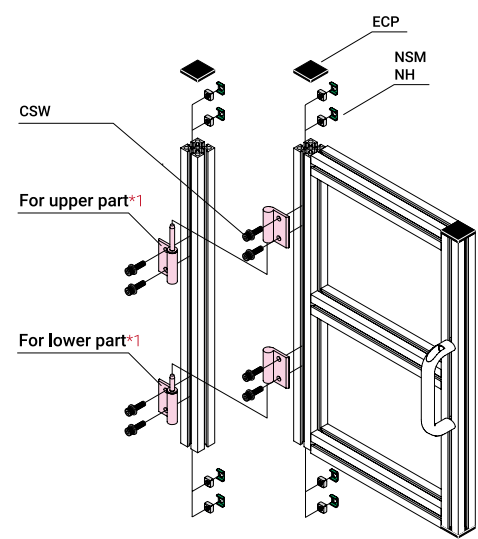

*1 Note there are two different attachment parts for upper and lower

Threaded fastener

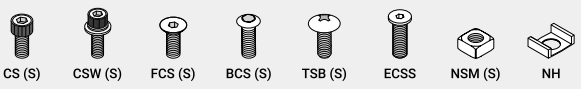



Specifications

วัสดุ Material	1 SUS304 2 Brass (Lead free)
การผิว Surface treatment	Mirror buffing

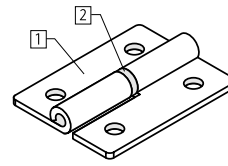

M6

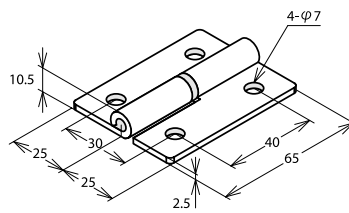

Specifications

Mass [g]	85.0
Allowable load	200N (2 pieces)

Accessories (Model Number)

Bolt	CSS-06-12 (4 pieces)
------	----------------------

Recommended Fastening Parts (Model Number)

Nut	NSMS-06-6 (4 pieces)
Nut Holder	NH-06-GR (4 pieces)

Model Number
DHF-5065-6-L (Left opening)
DHF-5065-6-R (right opening)

This describes DHF-5065-6-L

Example of use

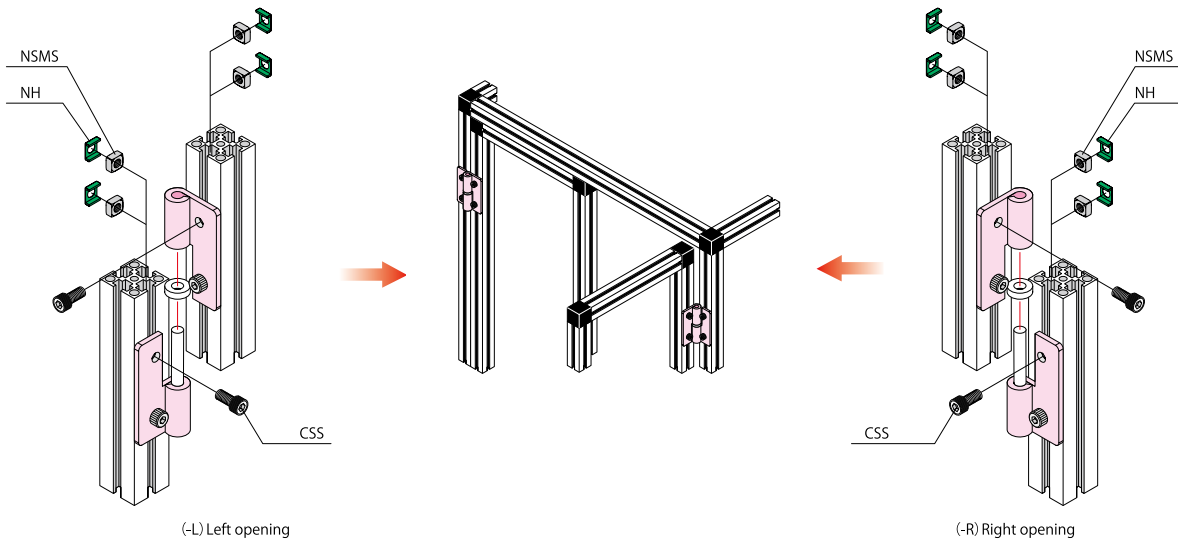

Accessory — ANCHOR BRACKET

Aluminium Frame

Bracket



Common Specifications

วัสดุ Material	SS400
การชุบ Surface treatment	Trivalent chromate
สี Color	Silver

Accessory

Bolts & Nuts

Rail Frame

Appendix

M6

Specifications

Mass [g]	340
----------	-----

Recommended Fastening Parts (Model Number)

Bolt	CSW-06-18 (2 pieces)
Nut	NSM-06-6 (2 pieces)
Nut Holder	NH-06-GR (2 pieces)

Model Number
ANCBK-3030L

M6

Specifications

Mass [g]	687
----------	-----

Recommended Fastening Parts (Model Number)

Bolt	CSW-06-18 (4 pieces)
Nut	NSM-06-6 (4 pieces)
Nut Holder	NH-06-GR (4 pieces)

Model Number
ANCBK-3060L

M6

Specifications

Mass [g]	594
----------	-----

Recommended Fastening Parts (Model Number)

Bolt	CSW-06-15 (4 pieces)
Nut	NSM-06-6 (4 pieces)
Nut Holder	NH-06-GR (4 pieces)

Model Number
ANCBK-3030B

M6

Specifications

Mass [g]	1048
----------	------

Recommended Fastening Parts (Model Number)

Bolt	CSW-06-15 (8 pieces)
Nut	NSM-06-6 (8 pieces)
Nut Holder	NH-06-GR (8 pieces)

Model Number
ANCBK-3060B

Example of use

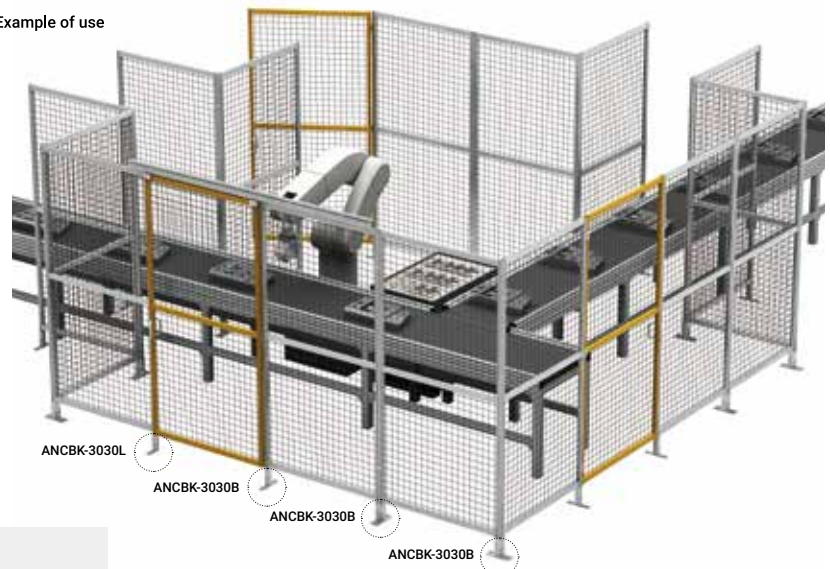

Threaded fastener

CS (S) CSW (S) FCS (S) BCS (S) TSB (S) ECSS NSM (S) NH

Accessory — LEVELLING FOOT BASE

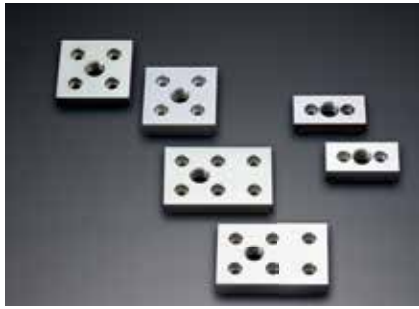

Common Specifications — Steel product (LFB)

วัสดุต้น Material	SS400
ชุบผิว Surface treatment	Trivalent chromate

Common Specifications — Aluminum product (LFA)

วัสดุต้น Material	A6063S-T5 / A6N01S-T5
ชุบผิว Surface treatment	Anodize Clear coat

Example of use

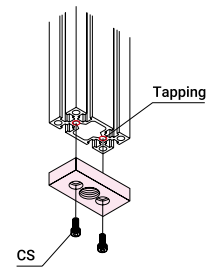

M4

Aluminum product
Model Number
LFA-2040-4

Specifications

Mass [g]	19
Thickness [t]	10

Recommended Fastening Parts (Model Number)

Bolt	CS-04-10 (2 pieces)
------	------------------------

M6

Steel product
Model Number
LFB-3060-6

Aluminum product
Model Number
LFA-3060-6

Specifications

Mass [g]	130
Thickness [t]	12

Recommended Fastening Parts (Model Number)

Bolt	CS-06-15 (2 pieces)
------	------------------------

Specifications

Mass [g]	60
Thickness [t]	15

Recommended Fastening Parts (Model Number)

Bolt	CS-06-18 (2 pieces)
------	------------------------

M6

Steel product
Model Number
LFB-6060-6

Aluminum product
Model Number
LFA-6060-6

Specifications

Mass [g]	295
Thickness [t]	12

Recommended Fastening Parts (Model Number)

Bolt	CSW-06-15 (4 pieces)
------	-------------------------

Specifications

Mass [g]	128
Thickness [t]	15

Recommended Fastening Parts (Model Number)

Bolt	CSW-06-18 (4 pieces)
------	-------------------------

M6

Steel product
Model Number
LFB-6090-6

Aluminum product
Model Number
LFA-6090-6

Specifications

Mass [g]	463
Thickness [t]	12

Recommended Fastening Parts (Model Number)

Bolt	CS-06-15 (6 pieces)
------	------------------------

Specifications

Mass [g]	196
Thickness [t]	15

Recommended Fastening Parts (Model Number)

Bolt	CS-06-18 (6 pieces)
------	------------------------

M8

Steel product
Model Number
LFB-4080-8

Aluminum product
Model Number
LFA-4080-8

Specifications

Mass [g]	346
Thickness [t]	16

Recommended Fastening Parts (Model Number)

Bolt	CS-08-20 (2 pieces)
------	------------------------

Specifications

Mass [g]	113
Thickness [t]	15

Recommended Fastening Parts (Model Number)

Bolt	CS-08-20 (2 pieces)
------	------------------------

M8

Steel product
Model Number
LFB-8080-8

Aluminum product
Model Number
LFA-8080-8

Specifications

Mass [g]	705
Thickness [t]	16

Recommended Fastening Parts (Model Number)

Bolt	CS-08-20 (4 pieces)
------	------------------------

Specifications

Mass [g]	233
Thickness [t]	15

Recommended Fastening Parts (Model Number)

Bolt	CS-08-20 (4 pieces)
------	------------------------

M8

Steel product
Model Number
LFB-MJ08

Specifications

Mass [g]	810
Thickness [t]	9

Recommended Fastening Parts (Model Number)

Bolt	CS-08-25 (4 pieces)
------	------------------------

M6 M8

Steel product
Model Number
LFB-S68

Specifications

Mass [g]	652
Thickness [t]	9

Example of use **M6 Series**

Recommended Fastening Parts (Model Number)

Bolt	CSW-06-20 (4 pieces)
Nut	NSM-06-6 (4 pieces)
Nut Holder	NH-06-GR (4 pieces)

Example of use **M8 Series**

Recommended Fastening Parts (Model Number)

Bolt	CSW-06-20 (4 pieces)
Nut	NSM-06-6 (4 pieces)
Nut Holder	NH-06-GR (4 pieces)

Accessory — BRACKET FOR LEVELLING FOOT

Aluminium Frame

Bracket



Accessory

Bolts & Nuts

Rail Frame

Appendix

M6

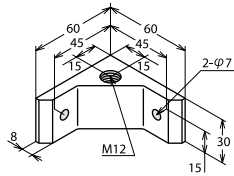

Model Number
ABLH-6030-6-LB

Specifications

วัสดุ Material	A6063S-T5 / A6N015-T5
การชุบผิว Surface treatment	Anodize
สี Color	Silver
Mass [g]	88

Recommended Fastening Parts (Model Number)

Bolt	CSW-06-20 (2 pieces)
Nut	NSM-06-6 (2 pieces)
Nut Holder	NH-06-GR (2 pieces)

Example of use

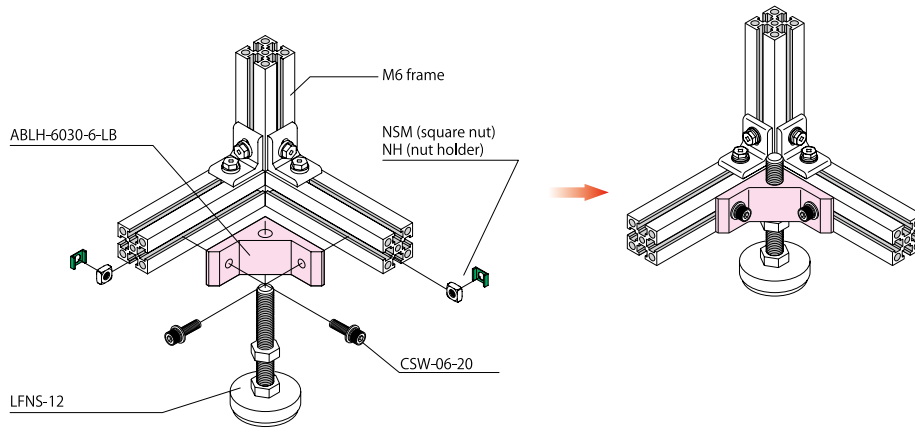

Threaded fastener

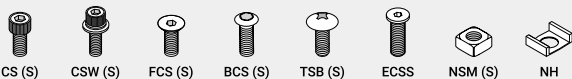

Accessory — LEVELLING FOOT



M4 M8

Model Number
LFN-08

Specifications

วัสดุ Material	1) SS400 2) CR
Mass [g]	80
Allowable load	2500N
สี Color	Silver

M6

Model Number
LFNF-06-43

Specifications

วัสดุ Material	1) SUS304 2) Aluminium
Mass [g]	80
Allowable load	2500N
สี Color	Silver

M6 M8

Model Number
LFF-16

Specifications

วัสดุ Material	1) SS400 (Equivalent) 2) SS400 (Forging)
Mass [g]	480
Allowable load	5000N
สี Color	Silver

Model Number
LFAP-16 Anchor plate for LFF-16

Specifications

วัสดุ Material	SPCC
Mass [g]	80
การบำบัดผิว Surface treatment	Trivalent chromate

M6 M8

Model Number
LFS60-16

Specifications

วัสดุ Material	1) SUS304 2) SUS304
Mass [g]	345.5
Allowable load	5000N
สี Color	Silver

Example of use

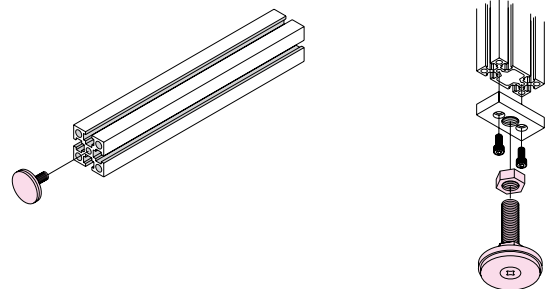

Accessory — CASTER UNIT

Aluminium Frame

Bracket



Accessory

Bolts & Nuts

Rail Frame

Appendix

M6 **M8**

Model Number
LFCB-S68 Caster base

Specifications

วัสดุ Material	SS400
Mass [g]	1049
ชุบผิว Surface treatment	Trivalent chromate

Example of use M6 Series

Recommended Fastening Parts (Model Number)

Bolt	CSW-06-20 (4 pieces)
Nut	NSM-06-6 (4 pieces)
Nut Holder	NH-06-GR (4 pieces)

Example of use M8 Series

Recommended Fastening Parts (Model Number)

Bolt	CSW-08-25 (4 pieces)
Nut	NSM-08-8 (4 pieces)
Nut Holder	NH-08-GR (4 pieces)

M6 **M8**

Model Number
C-100RS Flexible caster (with stopper)

Specifications

วัสดุ Material	1 Urethane Rubber 2 SS400
Mass [g]	1208
Allowable load	1020N
ชุบผิว Surface treatment	Trivalent chromate

Accessories

Bolt	CSW-10-15 (4 pieces)
------	----------------------

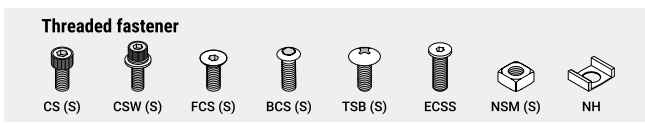
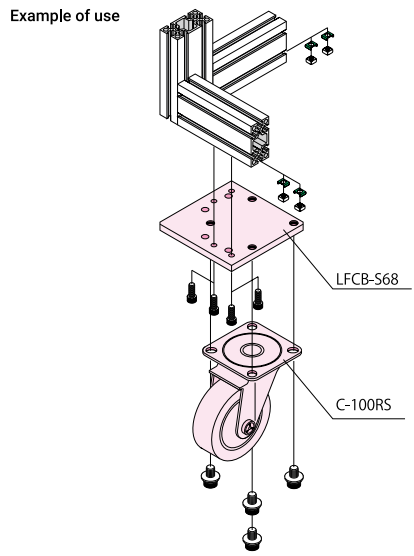



M6

Model Number
C-30

Specifications

วัสดุ Material	1 PA 2 SS400 3 SS400
Mass [g]	65
Allowable load	300N

Example of use

M6 **M8**

Model Number
CU-130

Specifications

วัสดุ Material	1 ADC-12 2 SS400 3 PA
Mass [g]	1080
Allowable load	1274N

Example of use

Recommended Fastening Parts (Model Number)

M6	
Bolt	CS-06-22 (4 pieces)
Nut	NSM-06-6 (4 pieces)
Nut Holder	NH-06-GR (4 pieces)
M8	
Bolt	CS-08-25 (4 pieces)
Nut	NSM-08-8 (4 pieces)
Nut Holder	NH-08-GR (4 pieces)

Accessory — MAGNET CATCH

Aluminium Frame

Bracket

Accessory

Bolts & Nuts

Rail Frame

Appendix

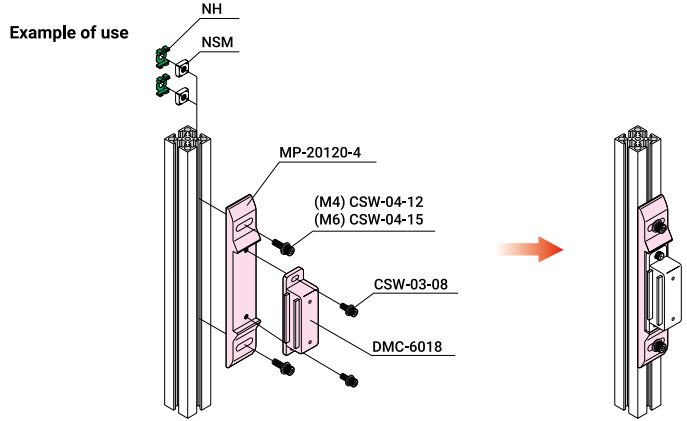

M4
M6

Model Number
DMC-6018

Specifications

วัสดุ Material	PE
Mass [g]	40
Adsorption power	24N

M4
M6

Model Number
MP-20120-4

Specifications

วัสดุ Material	A6N015-T5
Mass [g]	36.2
ชุบผิว Surface treatment	Anodize Clear coat

■ Use with M4/M6 Series

■ M4 Series

Recommended Fastening Parts (Model Number)

Bolt	CSW-03-08 (2 pieces) CSW-04-12 (2 pieces) FCS-03-06 (2 pieces)
Nut	NSM-04-3 (4 pieces)
Nut Holder	NH-04-GR (4 pieces)

■ M6 Series

Recommended Fastening Parts (Model Number)

Bolt	CSW-03-08 (2 pieces) CSW-04-15 (2 pieces) FCS-03-10 (2 pieces)
Nut	NSM-06-6 (4 pieces)
Nut Holder	NH-06-GR (4 pieces)

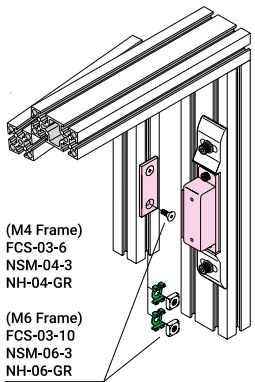

■ Use with Solid Door

■ M4 Series

Recommended Fastening Parts (Model Number)

Bolt	CSW-03-08 (2 pieces) CSW-04-12 (2 pieces) FCS-03-06 (2 pieces)
------	---

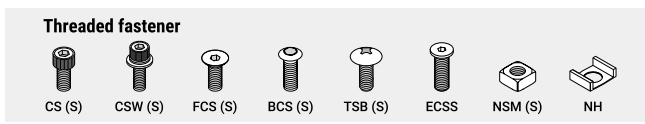
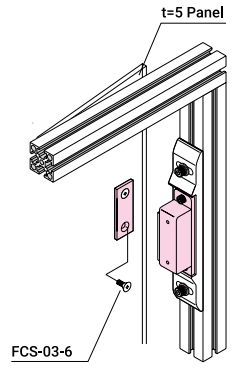



Common specifications

วัสดุ Material	1 3 SPCC
ชนิดผิว Surface treatment	1 Nickel plating 3 Trivalent chromate

Example of use

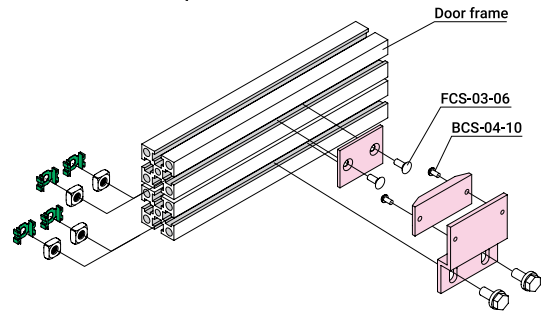

Aluminium Frame

Bracket

Accessory

Bolts & Nuts

Rail Frame

Appendix

M4	M6	M8
----	----	----

Model Number
DMCS-04

Specifications

Mass [g]	1 5 2 10 3 30
Adsorption power	10N

1

2

3

Accessories

Bolt	FCS-03-06 (2 pieces) BCS-03-05 (2 pieces)
------	--

M4	M6	M8
----	----	----

Model Number
DMCS-68

Specifications

Mass [g]	1 20 2 22 3 77
Adsorption power	30N

1

2

3

Accessories

Bolt	FCS-04-10 (2 pieces) BCS-03-06 (2 pieces)
------	--

Installation example

■ M4 Series

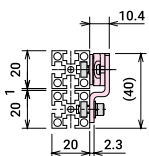

Recommended Fastening Parts (Model Number)

Bolt	CSW-04-10 (2 pieces)
Nut	NSM-04-3 (2 pieces) NSM-04-4 (2 pieces)
Nut holder	NH-04-GR (4 pieces)

■ M6 Series

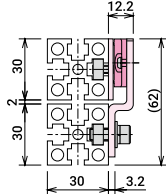

Recommended Fastening Parts (Model Number)

Bolt	CSW-06-15 (2 pieces)
Nut	NSM-06-4 (2 pieces) NSM-06-6 (2 pieces)
Nut holder	NH-06-GR (4 pieces)

■ M8 Series

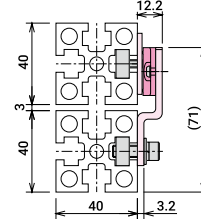

Recommended Fastening Parts (Model Number)

Bolt	CSW-06-18 (2 pieces)
Nut	NSM-08-4 (2 pieces) NSM-08-6 (2 pieces)
Nut holder	NH-08-GR (4 pieces)

Accessory — CLEAN MAGNET CATCH

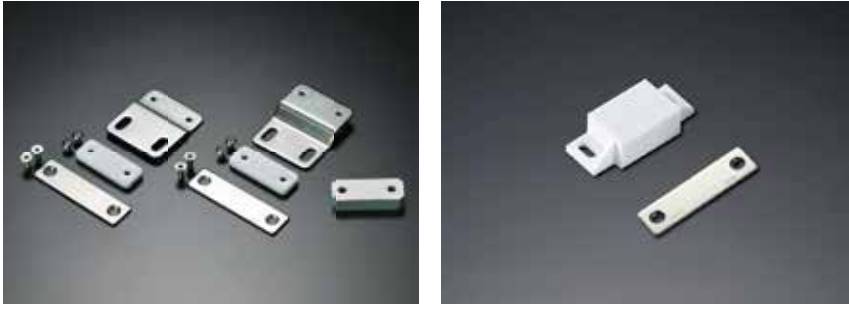

M4 M6 M8

Model Number CMCS-D10

Specifications

วัสดุ Material	1 SUS430 2 PP, Neodymium 3 SUS304
Mass [g]	1 17 2 8.5 3 32
Adsorption power	30N
การ Surface treatment	1 Foundation 3 Barrel finishing
สี Color	2 White

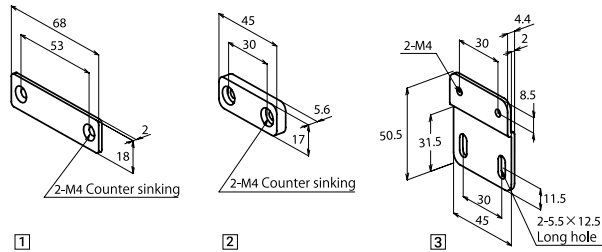

Accessories

Bolt	FCSS-04-08 (2 pieces) BCSS-04-05 (2 pieces)
------	--

M6 Series (Frame side)
+
M4 Series (Door side)

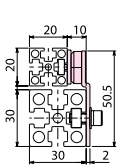

Recommended Fastening Parts (Model Number)

Bolt	CSWS-05-12 (2 pieces)
Nut	NSMS-04-4 (2 pieces) NSMS-06-5 (2 pieces)
Nut holder	NH-04-GR (2 pieces) NH-06-GR (2 pieces)

M8 Series (Frame side)
+
M6 Series (Door side)

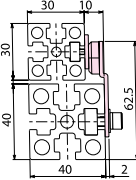

Recommended Fastening Parts (Model Number)

Bolt	CSWS-05-15 (2 pieces)
Nut	NSMS-06-4 (2 pieces) NSMS-08-5 (2 pieces)
Nut holder	NH-06-GR (2 pieces) NH-08-GR (2 pieces)

M8 Series (Frame side)
+
M4 Series (Door side)

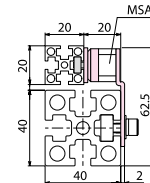

Recommended Fastening Parts (Model Number)

Bolt	CSWS-05-15 (2 pieces)
Nut	NSMS-04-4 (2 pieces) NSMS-08-5 (2 pieces)
Nut holder	NH-04-GR (2 pieces) NH-08-GR (2 pieces)

M6

Model Number CMCS-5021

Specifications

วัสดุ Material	1 SUS430 2 POM, Neodymium 3 SUS304
Mass [g]	1 17 2 21
Adsorption power	30N
การ Surface treatment	1 Foundation
สี Color	2 White

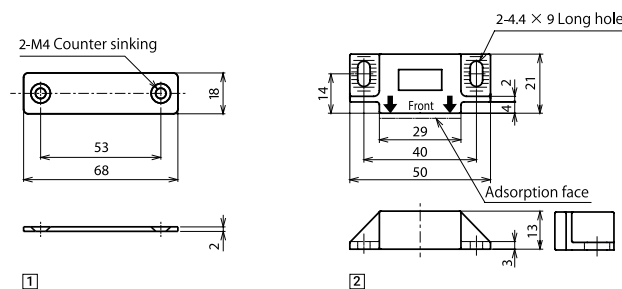

Recommended Fastening Parts (Model Number)

Bolt	FCSS-04-10 (2 pieces)
Nut	NSMS-06-4 (4 pieces)
Nut Holder	NH-06-GR (4 pieces)

Threaded fastener

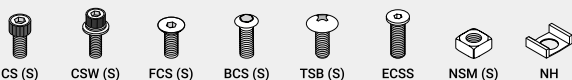

Accessory — STAINLESS STEEL LATCH



M6

Model Number
LT-06

Specifications

วัสดุ Material	SUS304
Mass [g]	50
การเคลือบ Surface treatment	Gloss polishing

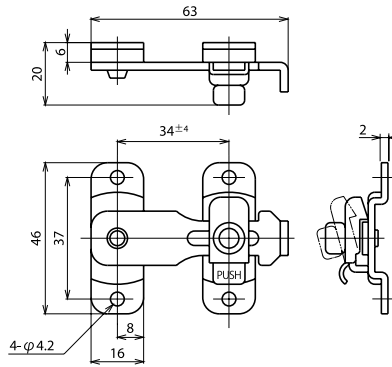

Recommended Fastening Parts (Model Number)

Bolt	CSS-04-12 (4 pieces)
Nut	NSMS-06-4 (4 pieces)
Nut holder	NH-06-GR (4 pieces)

How to use

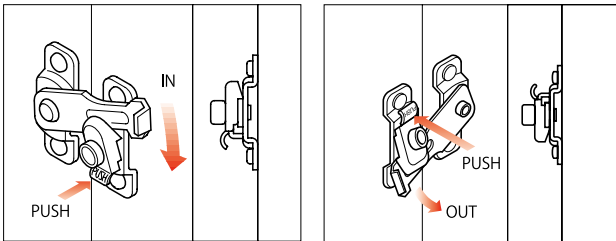

Accessory — HANDLE

Aluminium Frame

Bracket

Accessory

Bolts & Nuts

Rail Frame

Appendix



M4 **M6**

Model Number
HDL-0435-4

Specifications

Mass [g]	60
วัสดุต้น Material	ADC-12
ชุบผิว Surface treatment	Baking finish

Recommended Fastening Parts (Model Number)

M4	
Bolt	CS-04-10 (2 pieces)
Nut	NSMS-04-4 (2 pieces)
Nut Holder	NH-04-GR (2 pieces)
M6	
Bolt	CS-04-12 (2 pieces)
Nut	NSMS-06-4 (2 pieces)
Nut Holder	NH-06-GR (2 pieces)

M4

Model Number
HDL2-04-EL

Specifications

Mass [g]	94
วัสดุต้น Material	ADC-12
ชุบผิว Surface treatment	Baking finish

Example of use

Recommended Fastening Parts (Model Number)

Bolt	CS-04-15 (2 pieces)
Nut	NSMS-04-4 (2 pieces)
Nut Holder	NH-04-GR (2 pieces)

M6

Model Number
DTS-120

Specifications

Mass [g]	93
วัสดุต้น Material	SUS304

Example of use

Recommended Fastening Parts (Model Number)

Bolt	CSW-0-15 (2 pieces)
------	---------------------

Threaded fastener

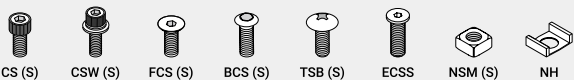

M6 **M8**

Example of use

Recommended Fastening Parts (Model Number)

M6	
Bolt	CS-06-20 (2 pieces)
Nut	NSMS-06-6 (2 pieces)
Nut Holder	NH-06-GR (2 pieces)
M8	
Bolt	CS-06-22 (2 pieces)
Nut	NSMS-08-6 (2 pieces)
Nut Holder	NH-08-GR (2 pieces)

Model Number
HDL2-06-EL

Specifications

Mass [g]	191
วัสดุ Material	ADC-12
ผิว Surface treatment	Baking finish

M6 **M8**

Example of use

Recommended Fastening Parts (Model Number)

M6	
Bolt	CS-06-28 (2 pieces)
M8	
Bolt	CS-06-35 (2 pieces)

Model Number
HDL2-0635-U

Specifications

Mass [g]	110
วัสดุ Material	ADC-12
ผิว Surface treatment	Baking finish

M6 **M8**

Example of use

Recommended Fastening Parts (Model Number)

M6	
Bolt	CS-06-18 (2 pieces)
Nut	NSMS-06-6 (2 pieces)
Nut Holder	NH-06-GR (2 pieces)
M8	
Bolt	CS-06-20 (2 pieces)
Nut	NSMS-08-6 (2 pieces)
Nut Holder	NH-08-GR (2 pieces)

Model Number
HDL2-0635-6

Specifications

Mass [g]	105
วัสดุ Material	ADC-12
ผิว Surface treatment	Baking finish

Accessory — GLASS RAIL

Aluminium Frame

Bracket

Accessory

Bolts & Nuts

Rail Frame

Appendix



Common specifications

Mass [g]	94
วัสดุ Material	ABS
Standard length [mm]	2000

Example of use

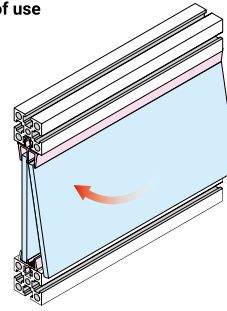

M4

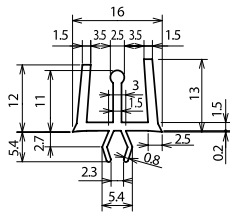

Model Number
PGRU-03-4-BK (Black)

Specifications

Mass [g]	144
----------	-----

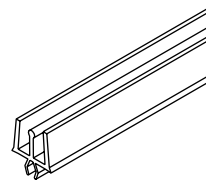

For UPPER side
Use with **PGRL-03-4**

M4

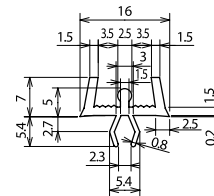

Model Number
PGRL-03-4-BK (Black)

Specifications

Mass [g]	110
----------	-----

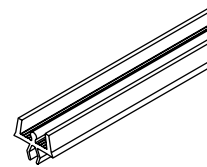

For LOWER side
Use with **PGRU-03-4**

M6

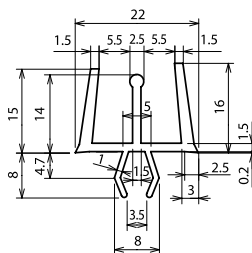

Model Number
PGRU-05-6-BK (Black)

Specifications

Mass [g]	236
----------	-----

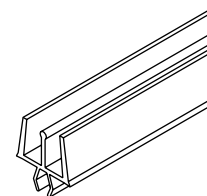

For UPPER side
Use with **PGRL-05-6**

About glass size

Size	Size	Thickness
M4	H=L-9.5mm	t=3mm
M6	H=L-12.5mm	t=5mm
M8	H=L-12.5mm	t=5mm

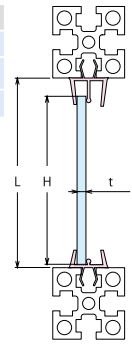

Cross-sectional view

M6

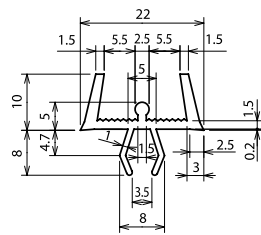

Model Number
PGRU-05-6-BK (Black)

Specifications

Mass [g]	166
----------	-----

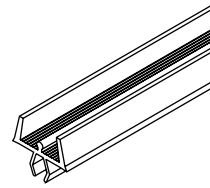

For LOWER side
Use with PGRU-05-6

M8

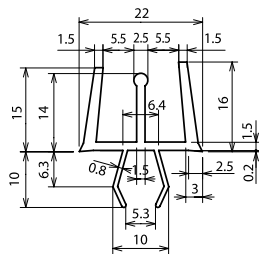

Model Number
PGRU-05-8-BK (Black)
PGRU-05-8-GY (Gray)

Specifications

Mass [g]	224
----------	-----

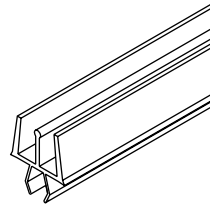

For UPPER side
Use with PGRU-05-8

M8

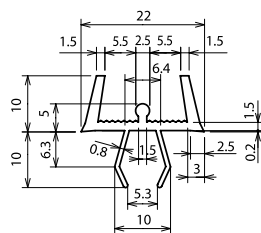

Model Number
PGRU-05-8-BK (Black)
PGRU-05-8-GY (Gray)

Specifications

Mass [g]	153
----------	-----

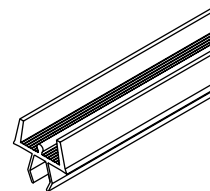

For LOWER side
Use with PGRU-05-8

Accessory — PANEL HOLDER

Aluminium Frame

Bracket

Accessory

Bolts & Nuts

Rail Frame

Appendix



Common specifications

วัสดุ Material	1 ABS 2 TPE
Mass [g]	238
Standard length	2000mm
สี Color	1 Gray 2 Natural

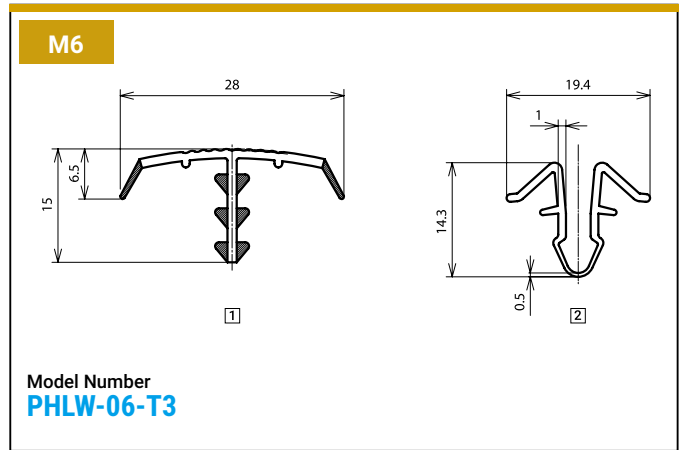
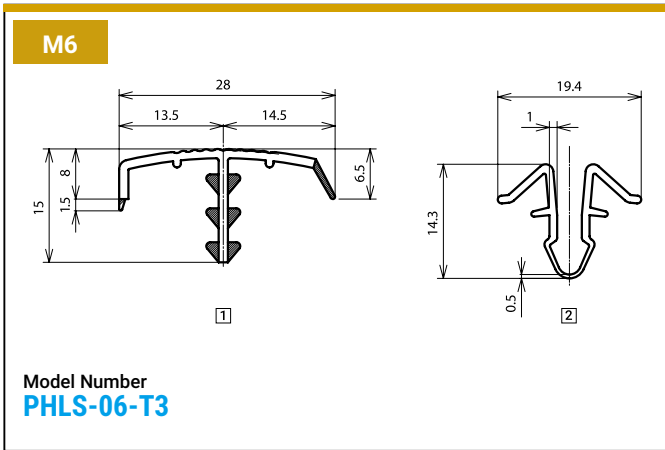

Example of use

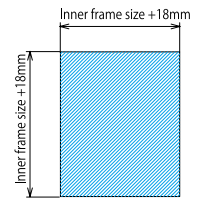
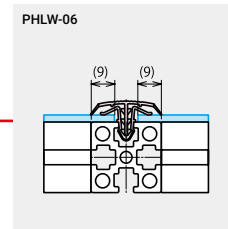
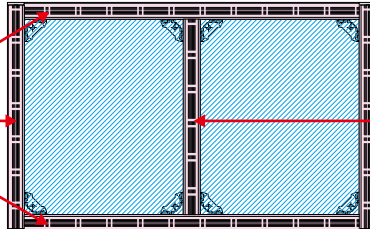
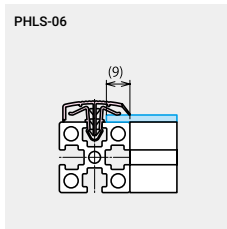

Accessory — FACE STRIPE



Common specifications

วัสดุ Material	PE
Standard length [mm]	2000

M4 For groove cover / Attache 3mm panel

Model Number
FS2-04-WH (White)
FS2-04-GY (Gray)

Specifications

Mass [g]	17
----------	----

M6 For groove cover / Attache 5mm panel

Model Number
FS2-06-WH (White)
FS2-06-GY (Gray)

Specifications

Mass [g]	21
----------	----

M8 For groove cover

Model Number
FS2-08-WH (White)
FS2-08-GY (Gray)

Specifications

Mass [g]	60
----------	----

M8 Attache 5mm panel

Model Number
FS2-08C-WH (White)

Specifications

Mass [g]	80
----------	----

Example of use for groove cover

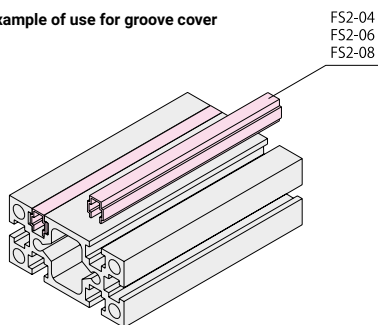

Example of use for attach the panel

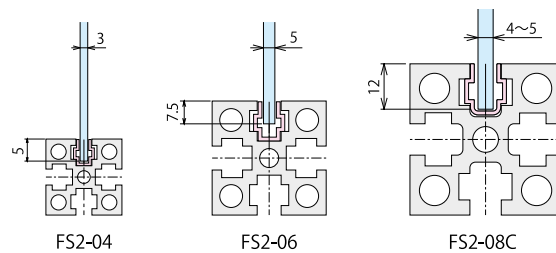

Accessory — SEALING MATERIALS

Aluminium Frame

Bracket

Accessory

Bolts & Nuts

Rail Frame

Appendix



M4

Model Number
PGP-04

Specifications

วัสดุ Material	TPE
Mass [g]	160
Standard length	2000mm
สี Color	Gray

M6

Model Number
PGP-06

Specifications

วัสดุ Material	TPE
Mass [g]	194
Standard length	2000mm
สี Color	Gray

M8

Model Number
PGP-08

Specifications

วัสดุ Material	TPE
Mass [g]	208
Standard length	2000mm
สี Color	Gray

M6 **M8**

Model Number
TY-6850

Specifications

วัสดุ Material	TPE
Mass [g]	330
Standard length	10000mm
สี Color	Gray

* Portion marked in red is detached. Depending on the use condition. (able to detached by hand)

M6

Model Number
PGS-06

Specifications

วัสดุ Material	TPE
Mass [g]	145
Standard length	2000mm
สี Color	Gray

Cross-sectional view

M6

Model Number
PGH-06

Specifications

วัสดุ Material	TPE
Mass [g]	200
Standard length	2000mm
สี Color	Gray

Accessory — TIE CLIP

Aluminium Frame

Bracket



Accessory

Bolts & Nuts

Rail Frame

Appendix

M4

M6

Model Number
ATC-46
ATC-46-P100 (100 pieces)

Specifications

วัสดุ Material	PA
Mass [g]	59 / 100 pcs

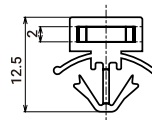
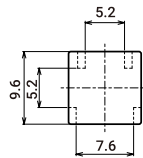

M6

M8

Model Number
ATC-68
ATC-68-P100 (100 pieces)

Specifications

วัสดุ Material	PA
Mass [g]	115 / 100 pcs

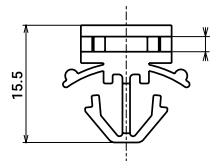
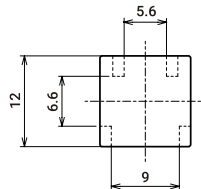

Example of use with clamping band

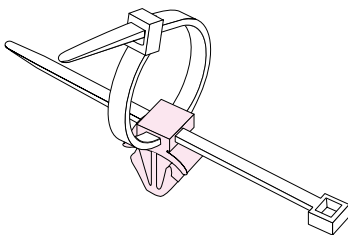

Example of use

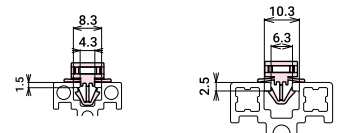

ATC-46

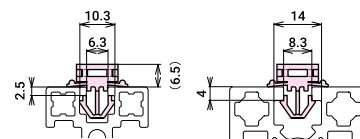

ATC-68

Accessory — SLIDE RAIL / SLIDER



M6

SLIDE RAIL

Model Number
ASR-1030

Specifications

วัสดุ Material	AL
Mass [g]	790
ชนิดผิว Surface treatment	Anodize
Standard length	2000mm
สี Color	Gray

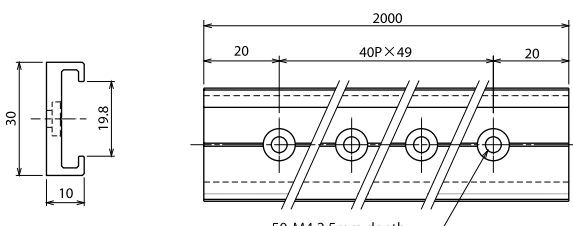

* It has 50 tap per one frame. Please prepare bolts and nuts by your requirement.

Recommended Fastening Parts (Model Number)

Bolt	BCS-04-10 (Requirement)
Nut	NSM-06-4 (Requirement)
Nut Holder	NH-06-GR (Requirement)

M6

SLIDER

Model Number
SRD-30

Specifications

วัสดุ Material	1) PE 2) SUS304
ชนิดผิว Surface treatment	1) High-Sliding Grade 2) Foundation
สี Color	1) Gray
Mass [g]	7

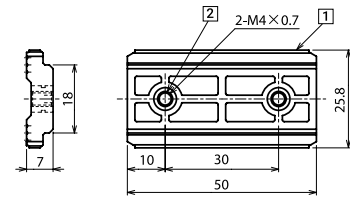

Recommended Fastening Parts (Model Number)

Bolt	CS-04-25 (2 pieces)
------	---------------------

External dimensions when attached slider to slide rail

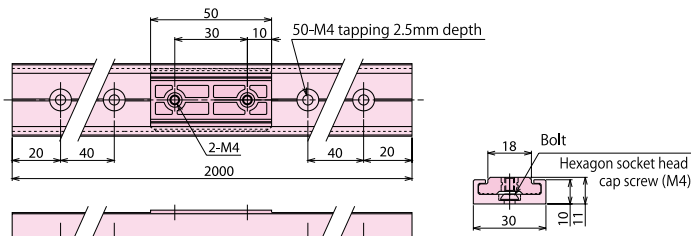

Example of use

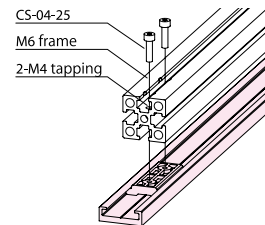

Threaded fastener

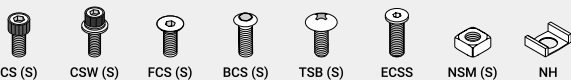

Bolts & Nuts

Hexagon socket head cap screw

Size	Pitch of thread	D		C		H		B	
		Max (Basic thread)	Max	Min	Max (Basic thread)	Min	Normal designation (Basic thread)	Min	
M3	0.5	5.5	5.5	2.87	3	2.86	2.5	2.52	
M4	0.7	7	7.22	3.44	4	3.82	3	3.02	
M5	0.8	8.5	8.72	4.58	5	4.82	4	4.02	
M6	1	10	10.22	5.72	6	5.7	5	5.02	
M8	1.25	13	13.27	6.86	8	7.64	6	6.02	

Unit: mm



Steel bolts

Specifications

Material	Surface treatment	Tensile strength rank	Color
SCM435	Trivalent chromate	10.9	Silver

Size	Length [mm]	Model Number	Mass [g/piece]
M3	12	CS-03-12	0.9
M4	5	CS-04-05	1.3
	8	CS-04-08	1.5
	10	CS-04-10	1.6
	12	CS-04-12	1.8
	15	CS-04-15	2.0
	18	CS-04-18	2.2
M5	20	CS-04-20	2.4
	8	CS-05-08	2.6
	10	—	—
	12	CS-05-12	3.1
	15	CS-05-15	3.5
M6	18	CS-05-18	3.8
	20	CS-05-20	4.1
	12	CS-06-12	4.8
	15	CS-06-15	5.2
	18	CS-06-18	5.8
	20	CS-06-20	6.0
	22	CS-06-22	6.5
	25	CS-06-25	6.9
	28	CS-06-28	7.5
	30	CS-06-30	7.8
M8	35	CS-06-35	9.1
	40	CS-06-40	10.2
	15	CS-08-15	11.0
	18	CS-08-18	12.0
	20	CS-08-20	12.5
	22	CS-08-22	13.2
	25	CS-08-25	14.2
	28	CS-08-28	15.0
	30	CS-08-30	15.7
	35	CS-08-35	17.3
40	CS-08-40	19.4	

Stainless steel bolts

Specifications

Material	Surface treatment	Tensile strength rank
SUS XM7	N/A	A2-70

Size	Length [mm]	Model Number	Mass [g/piece]
M3	12	—	—
M4	5	—	—
	8	CSS-04-08	1.5
	10	CSS-04-10	1.7
	12	CSS-04-12	1.8
	15	CSS-04-15	2.0
	18	CSS-04-18	2.3
M5	20	CSS-04-20	2.3
	8	—	—
	10	CSS-05-10	2.9
	12	CSS-05-12	3.2
	15	CSS-05-15	3.5
M6	18	—	—
	20	—	—
	12	CSS-06-12	4.7
	15	CSS-06-15	5.4
	18	CSS-06-18	5.9
	20	CSS-06-20	6.2
	22	CSS-06-22	6.4
	25	CSS-06-25	7.1
	28	CSS-06-28	7.5
	30	CSS-06-30	8.0
M8	35	—	—
	40	—	—
	15	CSS-08-15	11.0
	18	CSS-08-18	11.9
	20	CSS-08-20	12.5
	22	CSS-08-22	13.2
	25	CSS-08-25	14.5
	28	CSS-08-28	15.3
	30	CSS-08-30	15.7
	35	CSS-08-35	17.6
40	CSS-08-40	19.5	

Hexagon socket head cap screw with captive washer

Size	Pitch of thread	D		C		H		B		Plain washer		Spring washer	
		Max (Basic thread)	Max	Min	Max (Basic thread)	Min	Normal designation (Basic thread)	Min	D1	T2	D2	T2	
M4	0.7	7	7.22	3.44	4	3.82	3	3.02	10	0.8	7	1	
M5	0.8	8.5	8.72	4.58	5	4.82	4	4.02	12	0.8	8.5	1.3	
M6	1	10	10.22	5.72	6	5.7	5	5.02	13	1	11.5	1.5	
M8	1.25	13	13.27	6.86	8	7.64	6	6.02	18 [17]	1.6	14.5	2	

Unit: mm

Steel bolts
Stainless steel bolts

Steel bolts

Specifications

Material	Surface treatment	Tensile strength rank	Color
SCM435	Trivalent chromate	10.9	Silver

Size	Length [mm]	Model Number	Mass [g/piece]
M4	10	CSW-04-10	2.1
	12	CSW-04-12	2.3
	15	CSW-04-15	2.5
	18	CSW-04-18	2.8
M5	12	—	—
	15	—	—
	18	—	—
M6	15	CSW-06-15	6.8
	18	CSW-06-18	7.5
	20	CSW-06-20	7.8
M8	20	CSW-08-20	16.3
	22	CSW-08-22	17.1
	25	CSW-08-25	18.1

Stainless steel bolts

Specifications

Material	Surface treatment	Tensile strength rank
SUS XM7	N/A	A2-70

Size	Length [mm]	Model Number	Mass [g/piece]
M4	10	CSWS-04-10	2.1
	12	CSWS-04-12	2.3
	15	CSWS-04-15	2.5
	18	—	—
M5	12	CSWS-05-12	4.1
	15	CSWS-05-15	4.5
	18	CSWS-05-18	4.7
M6	15	CSWS-06-15	6.8
	18	CSWS-06-18	7.7
	20	CSWS-06-20	8.1
M8	20	CSWS-08-20	16.6
	22	—	—
	25	CSWS-08-25	18.2

Hexagon socket countersunk head screw

Size	Pitch of thread	D		H		h		B		C	
		Basic dimension	Tolerance	Basic dimension	Tolerance	Reference	Basic dimension	Tolerance	About		
M3	0.5	6	0 -0.30	1.7	0 -0.14	0.2	2	+0.08 +0.02	2.3		
M4	0.7	8	0 -0.36	2.3	0 -0.14	0.3	2.5	+0.08 +0.02	2.9		
M5	0.8	10	0 -0.36	2.8	0 -0.14	0.3	3	+0.08 +0.02	3.5		
M6	1	12	0 -0.43	3.3	0 -0.18	0.3	4	+0.105 +0.03	4.7		
M8	1.25	18	0 -0.46	4.4	0 -0.18	0.4	5	+0.105 +0.03	5.9		

Unit: mm

Steel bolts
Stainless steel bolts

Steel bolts

Specifications

Material	Surface treatment	Tensile strength rank	Color
SCM435	Trivalent chromate	10.9	Silver

Size	Length [mm]	Model Number	Mass [g/piece]
M3	4	FCS-03-04	0.2
	6	FCS-03-06	0.3
	10	FCS-03-10	0.5
M4	8	FCS-04-08	0.8
	10	FCS-04-10	1.0
M5	12	FCS-04-12	1.1
	12	FCS-05-12	1.9
M6	15	FCS-05-15	2.2
	14	FCS-06-14	3.2
M8	18	FCS-06-18	3.8
	18	FCS-08-18	7.7
	22	FCS-08-22	8.9

Stainless steel bolts

Specifications

Material	Surface treatment	Tensile strength rank
SUS XM7	N/A	A2-50

Size	Length [mm]	Model Number	Mass [g/piece]
M3	4	FCSS-03-04	0.2
	6	FCSS-03-06	0.3
	10	FCSS-03-10	0.5
M4	8	FCSS-04-08	0.8
	10	FCSS-04-10	1.0
M5	12	FCSS-04-12	1.1
	12	—	—
M6	15	—	—
	14	FCSS-06-14	3.3
M8	18	FCSS-06-18	4.0
	18	FCSS-08-18	7.8
	22	FCSS-08-22	9.0

Aluminium Frame
Bracket
Accessory
Bolts & Nuts
Rail Frame
Appendix

Bolts & Nuts

Hexagon socket button head screw



Steel bolts



Stainless steel bolts

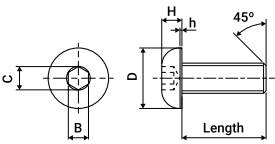

Size	Pitch of thread	D		H		h	B		C	
		Basic dimension	Tolerance	Basic dimension	Tolerance	Reference	Basic dimension	Tolerance	About	
M4	0.7	7.5	0 -0.3	2.6	±0.15	0.4	2.5	+0.08 +0.02	2.9	
M6	1	10.5	0 -0.4	4	±0.2	0.8	4	+0.105 +0.03	4.7	
M8	1.25	14	0 -0.5	5	±0.2	0.8	5	+0.105 +0.03	5.9	

Unit: mm

Steel bolts

Specifications

วัสดุ Material	ชุบผิว Surface treatment	Tensile strength rank	สี Color
SCM435	Trivalent chromate	10.9	Silver

Size	Length [mm]	Model Number	Mass [g/piece]
M4	5	BCS-04-05	0.9
	8	BCS-04-08	1.1
	10	BCS-04-10	1.2
	15	—	—
M6	12	BCS-06-12	3.6
	14	BCS-06-14	4.0
M8	15	BCS-08-15	8.3
	18	BCS-08-18	9.3

Stainless steel bolts

Specifications

วัสดุ Material	ชุบผิว Surface treatment	Tensile strength rank
SUS XM7	N/A	A2-50

Size	Length [mm]	Model Number	Mass [g/piece]
M4	5	BCSS-04-05	0.8
	8	—	—
	10	—	—
	15	BCSS-04-15	1.9
M6	12	BCSS-06-12	3.3
	14	—	—
M8	15	—	—
	18	—	—

Truss head screw



Steel bolts



Stainless steel bolts

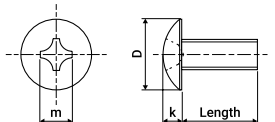

Size	Pitch of thread	D		K	m
		Max (basic dimension)	Max (basic dimension)	Max (basic dimension)	Normal designation (basic dimension)
M4	0.7	9.4	2.5	4.3	
M5	0.8	11.8	3.1	5.0	
M8	1	14	3.7	6.3	

Unit: mm

Steel bolts

Specifications

วัสดุ Material	ชุบผิว Surface treatment	สี Color
SWCH (Equivalent)	Trivalent chromate	Silver

Size	Length [mm]	Model Number	Mass [g/piece]
M4	10	TSB-04-10	1.4
M5	10	TSB-05-10	2.6
M6	12	TSB-06-12	4.5
	15	TSB-06-15	5.0
	25	TSB-06-25	6.7

Stainless steel bolts

Specifications

วัสดุ Material	ชุบผิว Surface treatment
SUS XM7	N/A

Size	Length [mm]	Model Number	Mass [g/piece]
M4	10	TSBS-04-10	1.5
M5	10	—	—
M6	12	TSBS-06-12	4.5
	15	TSBS-06-15	5.0
	25	TSBS-06-25	6.7

Special low head hexagonal socket cap screw



Stainless steel bolts

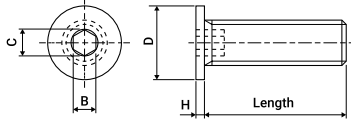

Size	Pitch of thread	Unit: mm			
		D Basic dimension	H Basic dimension	B Basic dimension	C About
M6	1	10	1.5	3	3.5
M8	1.25	13	1.5	4	4.7

Stainless steel bolts

Specifications

วัสดุ Material	ผิว Surface treatment
SUS XM7	N/A

Size	Length [mm]	Model Number	Mass [g/piece]
M6	16	ECSS-06-16	3.3
M8	25	ECSS-08-25	8.5

Special high head hexagonal socket cap screw



Stainless steel bolts

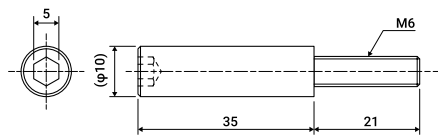

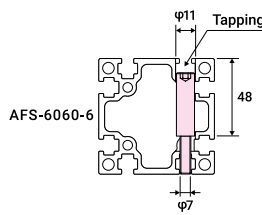

Fastening can be done by wrenches on the market. Inserted bolt does not fall.

Stainless steel bolts

Specifications

วัสดุ Material	ผิว Surface treatment	Tensile strength rank
SUS 304 (Equivalent)	N/A	A2-70

Size	Length [mm]	Model Number	Mass [g/piece]
M6	21	HCSS35-06-21	24.3

Bolts & Nuts

Square nut



Steel nut

Stainless steel nut

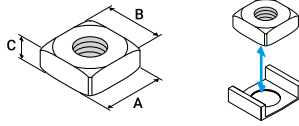

Frame Size	A	B	C
M4	8	8	3.2
M6	10	10	5
M8	13.7	13.7	6.5

Unit: mm

Steel nut

Specifications

วัสดุ Material	ผิว Surface treatment	สี Color
SWCH (Equivalent)	Trivalent chromate	Silver

Frame size	Bolt size	Model Number	Mass [g/piece]
M4 Frame	M3	NSM-04-3	1.2
	M4	NSM-04-4	1.1
M6 Frame	M3	NSM-06-3	3.2
	M4	NSM-06-4	3.1
	M5	NSM-06-5	2.9
	M6	NSM-06-6	2.6
M8 Frame	M4	NSM-08-4	7.9
	M5	NSM-08-5	7.7
	M6	NSM-08-6	7.3
	M8	NSM-08-8	6.4

Stainless steel nut

Specifications

วัสดุ Material	ผิว Surface treatment
SUS XM7	N/A

Frame size	Bolt size	Model Number	Mass [g/piece]
M4 Frame	M3	NSMS-04-3	1.1
	M4	NSMS-04-4	1.1
M6 Frame	M3	NSMS-06-3	3.0
	M4	NSMS-06-4	3.0
	M5	NSMS-06-5	2.7
	M6	NSMS-06-6	2.5
M8 Frame	M4	NSMS-08-4	7.6
	M5	NSMS-08-5	7.5
	M6	NSMS-08-6	7.2
	M8	NSMS-08-8	6.6

Nut holder

M4

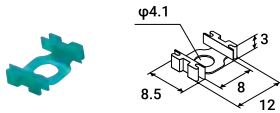

M6

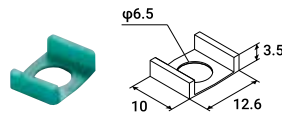

M8

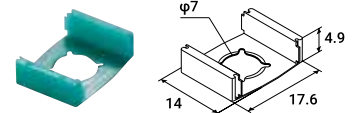

Specifications

วัสดุ Material	สี Color
POM	Green

Frame size	Nut size]	Model Number	Mass [g/piece]
M4 Frame	M4 Square nut	NH-04-GR	0.1
M6 Frame	M6 Square nut	NH-06-GR	0.1
M8 Frame	M8 Square nut	NH-08-GR	0.3

Nut

* Use it with nut holder

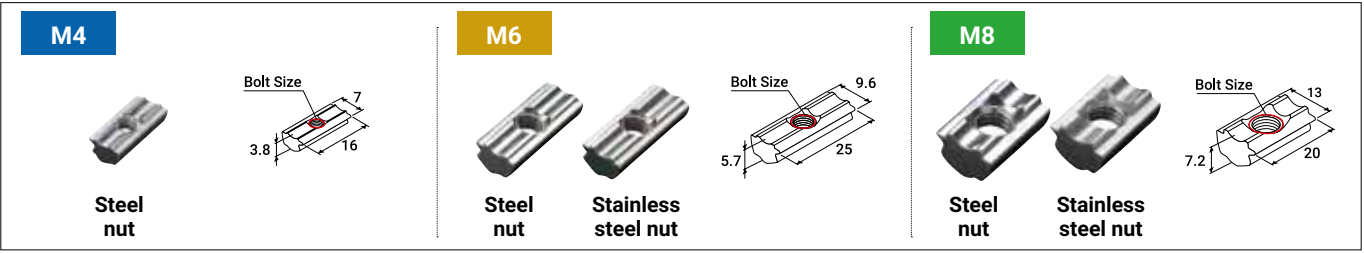

Steel nut

Specifications

วัสดุ Material	ผิว Surface treatment	สี Color
SWCH (Equivalent)	Trivalent chromate	Silver

Frame size	Bolt size	Model Number	Mass [g/piece]
M4 Frame	M3	NAMT-04-3	2.3
	M4	NAMT-04	2.2
M6 Frame	M3	NAMT-06-3	8.4
	M4	NAMT-06-4	8.1
	M5	NAMT-06-5	7.8
	M6	NAMT-06	7.5
M8 Frame	M4	NAMT-08-4	11.1
	M5	NAMT-08-5	10.7
	M6	NAMT-08-6	10.3
	M8	NAMT-08	9.0

Stainless steel nut

Specifications

วัสดุ Material	ผิว Surface treatment
SUS XM7	N/A

Frame size	Bolt size	Model Number	Mass [g/piece]
M4 Frame	M3	—	—
	M4	—	—
M6 Frame	M3	NAMS-06-3	8.4
	M4	NAMS-06-4	8.2
	M5	NAMS-06-5	7.8
	M6	NAMS-06	7.5
M8 Frame	M4	NAMS-08-4	11.0
	M5	NAMS-08-5	10.7
	M6	NAMS-08-6	10.3
	M8	NAMS-08	8.9

Nut holder

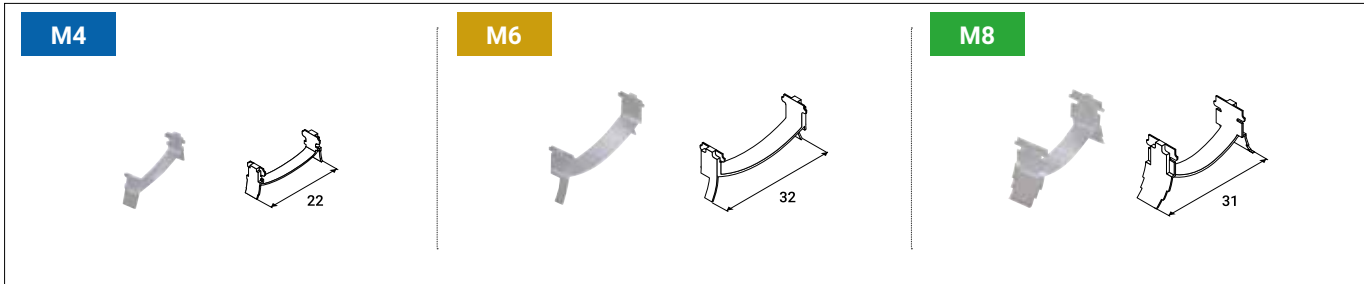

Specifications

วัสดุ Material	สี Color
M4: PE M6/M8: PP	Natural

Frame size	Nut size]	Model Number	Mass [g/piece]
M4 Frame	M4 nut	NHA-04	0.1
M6 Frame	M6 nut	NHA-06	0.1
M8 Frame	M8 nut	NHA-08	0.2

Usage instructions

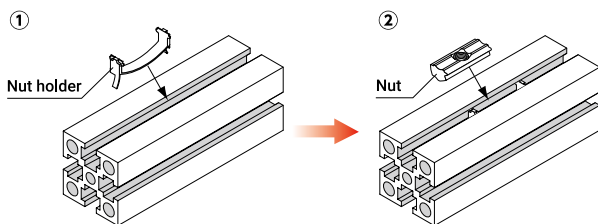

- ① Insert nut holder to T slot.
- ② Refer to the description on the right to insert nut.

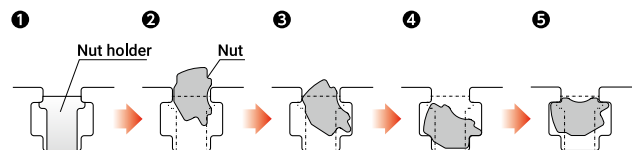

- ①~⑤ Insert as sliding nut after pushing nut holder to frame T slot.

Rail Frame



Aluminium Frame

Bracket

Accessory

Bolts & Nuts

Rail Frame

Appendix

M6

RAIL FRAME



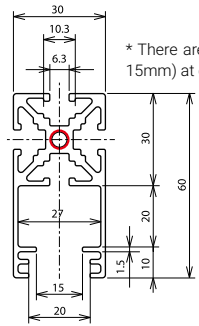

* There are M6 tapping (depth 15mm) at edge of frame.

Specifications

วัสดุต้น Material	ชนิดผิว Surface treatment	ขนาดที่ลดจำหน่าย Sellable dimensions [mm] unit	พื้นที่หน้าตัด Sectional area [mm ²]	มวล Mass [kg/m]	ค่าความต้านทานแรงดึง Tensile strength	พื้นที่หน้าตัดส่วนใน Moment of inertia of area Ix[mm ⁴] Iy[mm ⁴]	
A6063S-T5 / A6N015-T5	Anodize	15 ~ 4,000	487.1	1.315	225 N/mm ²	14.3 x 10 ⁴	5.5 x 10 ⁴

Model Number
AFRS-3060-6

About hanging width and load

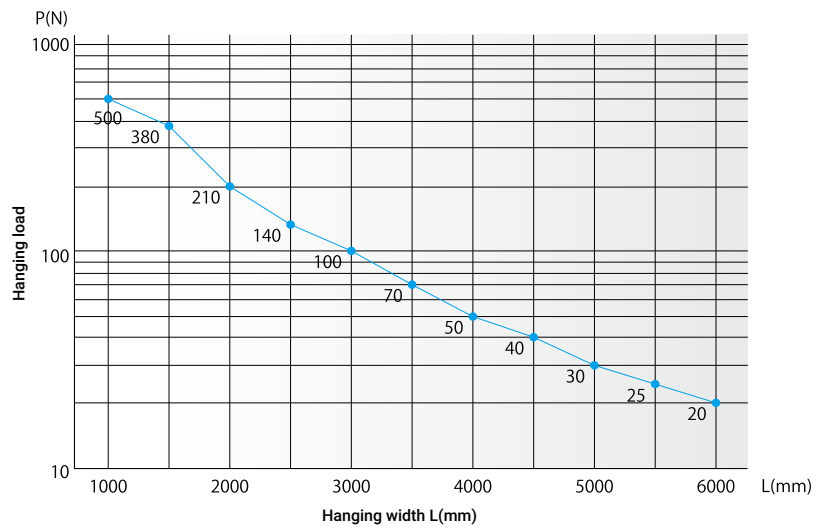
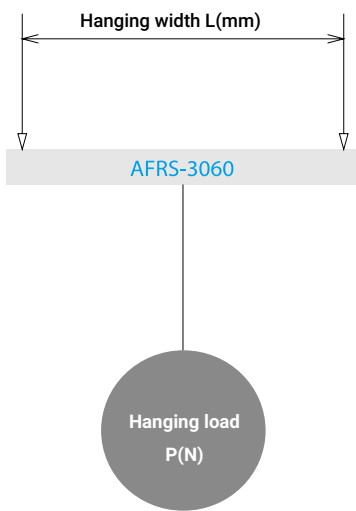

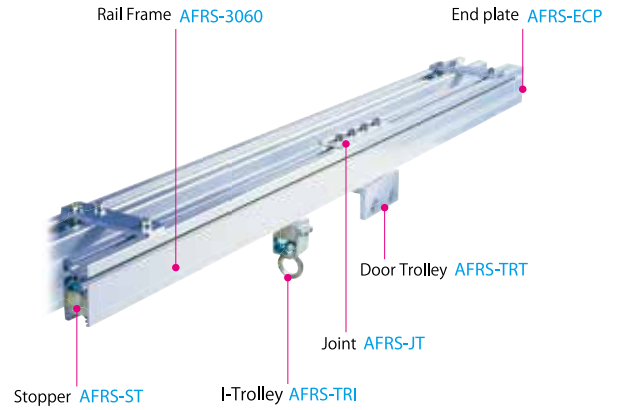

M6 I-TROLLEY



Model Number
AFRS-TRI

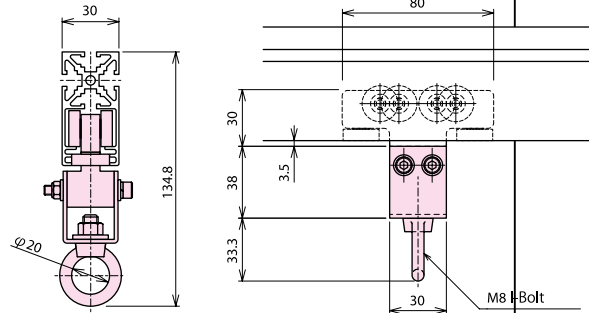

Specifications

วัสดุ Main Material	สามารถรับโหลดได้ Allowable load [N]	มวล Mass [kg/m]
Main unit: AC3A / I-Bolt: SUS304 / Roller: POM	200	236

M6 DOOR TROLLEY



Model Number
AFRS-TRT

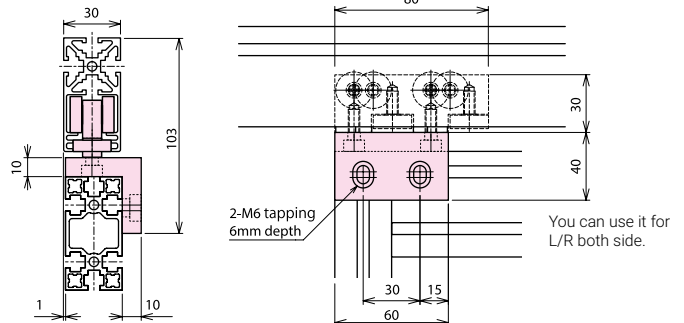

Specifications

วัสดุ Main Material	สามารถรับโหลดได้ Allowable load [N]	มวล Mass [kg/m]	Accessories
Main unit: A6063S-T5 / A6N01S-T5 / Bolt: SCM435 / Roller: POM	400 (2 pieces)	205	<ul style="list-style-type: none"> CS-06-12 (2 pieces) Hexagon socket headcap screw M6x15 (2 pieces)

M6 JOINT



Model Number
AFRS-JT

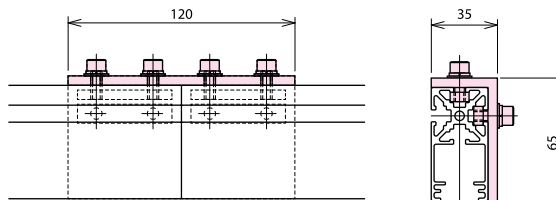

Specifications

วัสดุ Main Material	มวล Mass [kg/m]	Accessories
Main unit: A6N01S-T5 / Bolt: SCM435 / Nut: SS400 (Equivalent)	245	<ul style="list-style-type: none"> NSL-06 (4 pieces) NH-06-GR (4 pieces) Hexagon socket headcap screw M6x15 (8 pieces)

Rail Frame

Aluminium Frame

Bracket

Accessory

Bolts & Nuts

Rail Frame

Appendix

M6 STOPPER

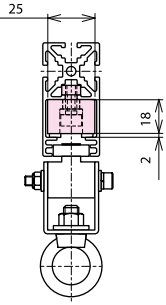
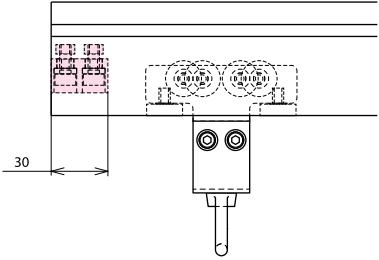
Model Number
AFRS-ST

Specifications

วัสดุชิ้น Material	มวล Mass [kg/m]
Main unit: Urethane rubber / Bolt: SCM435 / Nut: SWCH (Equivalent)	33

Accessories

- CS-06-15 (2 pieces)
- NSML-06-6 (2 pieces)
- NH-06-GR (2 pieces)

M6 END PLATE

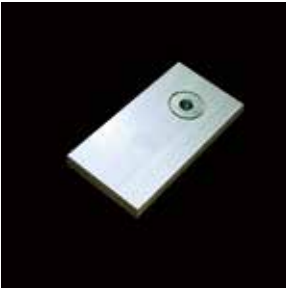
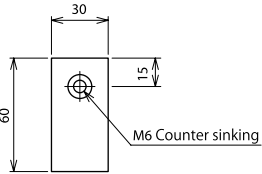
Model Number
AFRS-ECP

Specifications

วัสดุชิ้น Material	มวล Mass [kg/m]
Main unit: A6063S-T5 / A6N015-T5 / Bolt: SCM435	26.6

Accessories

- FCS-06-18 (1 piece)

Example of use Dorr trolley AFRS-TRT



Example of use Joint AFRS-JT



Example of use Stopper AFRS-ST



Spot facing

Standard spot facing

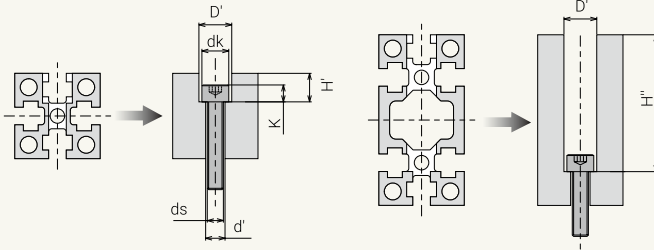

Dimensions [mm]	ds	d'	dk	D'	K	H'	H''
M4 frame	4	4.5	7	8	4	7.5	32
M6 frame	6	6.6	10	11	6	11	48
M8 frame	8	8.6	13	14	8	15.5	64

* You may have case spot facing is not possible and tightening bolt torque is limited (refer below).

Connect with additional machining on Alfa Frame

- ❶ Necessary to tap on the edge of Alfa Frame.
- ❷ Necessary to tap on the edge of Alfa Frame.
- ❸ Connect to use hexagon socket head cap screw.

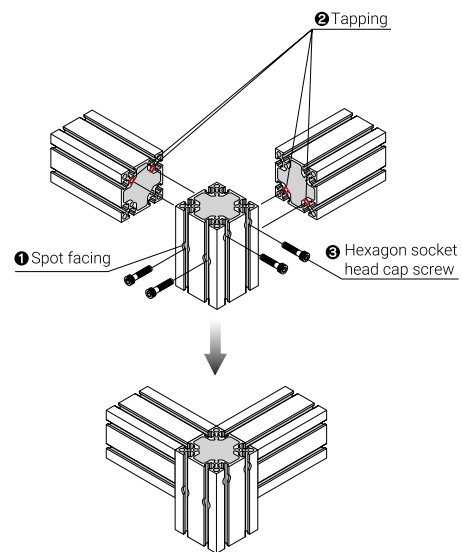
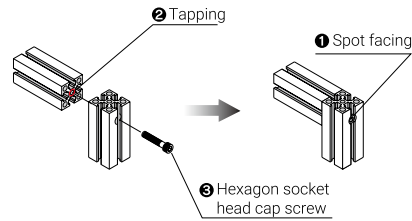

Spot facing				
	Frame	Standard	Inadvisable	Impossibility
M4	AFS-2020-4	✓		
	AFS-2040-4	✓		
	AFS-2060-4	✓		
	AFS-4040-4	✓		
M6	AFS-3030-6	✓		
	AFS-3030L-6(-YE)	✓		
	AFS-3030F-6			Tightening torque: 5.6 N·m
	AFS-3060-6	✓		
	AFS-3060L-6(-YE)	✓		
	AFS-3060F-6			Tightening torque: 5.6 N·m
	AFS-3090-6			Tightening torque: 5.6 N·m
	AFS-30120-6			Tightening torque: 5.6 N·m
	AFS-6060-6	✓		
	AFS-6060L-6	✓		
	AFS-6060F-6			Tightening torque: 5.6 N·m
	AFS-6090B-6	✓		
	AFSB-15120-6	✓		
	M8	AFS-4040-8	✓	
AFS-4040L-8(-YE)				Tightening torque: 15.0 N·m
AFS-4040F-8			✓	
AFS-4080-8		✓		
AFS-4080L-8(-YE)				Tightening torque: 15.0 N·m
AFS-4080F-8			✓	
AFS-40160-8				Tightening torque: 15.0 N·m
AFS-4545L-8				Tightening torque: 15.0 N·m
AFS-4590B-8				Tightening torque: 15.0 N·m
AFS-5050-8				Tightening torque: 15.0 N·m
AFS-50100-8				Tightening torque: 15.0 N·m
AFS-8080-8		✓		
AFS-8080L-8				Tightening torque: 15.0 N·m
AFS-8080F-8			✓	
AFS-80160-8				Tightening torque: 15.0 N·m
AFS-9090L-8				Tightening torque: 15.0 N·m
AFS-90180L-8			Tightening torque: 15.0 N·m	
AFS-100100C-8			Tightening torque: 15.0 N·m	

Comparison chart for Flexural rigidit

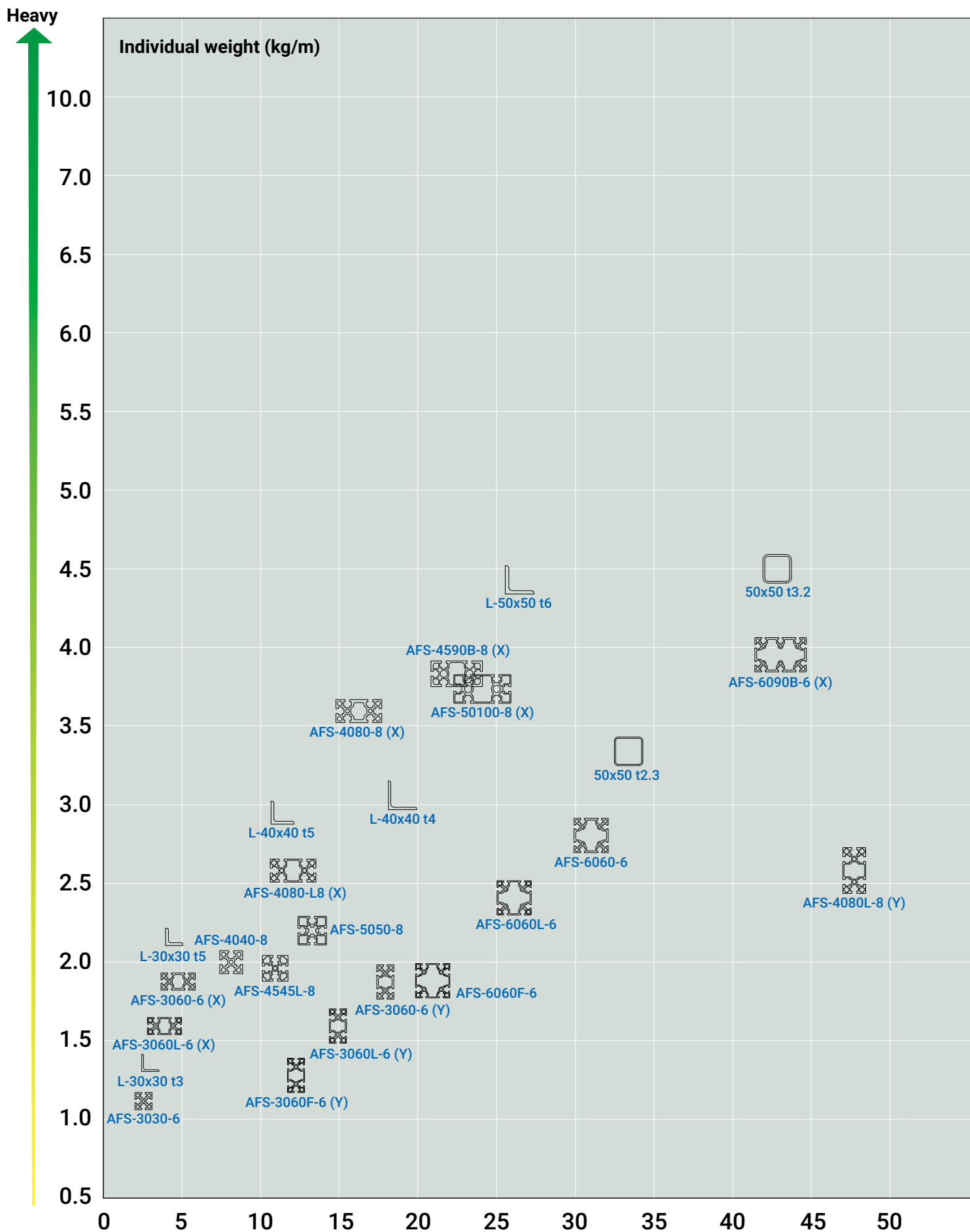

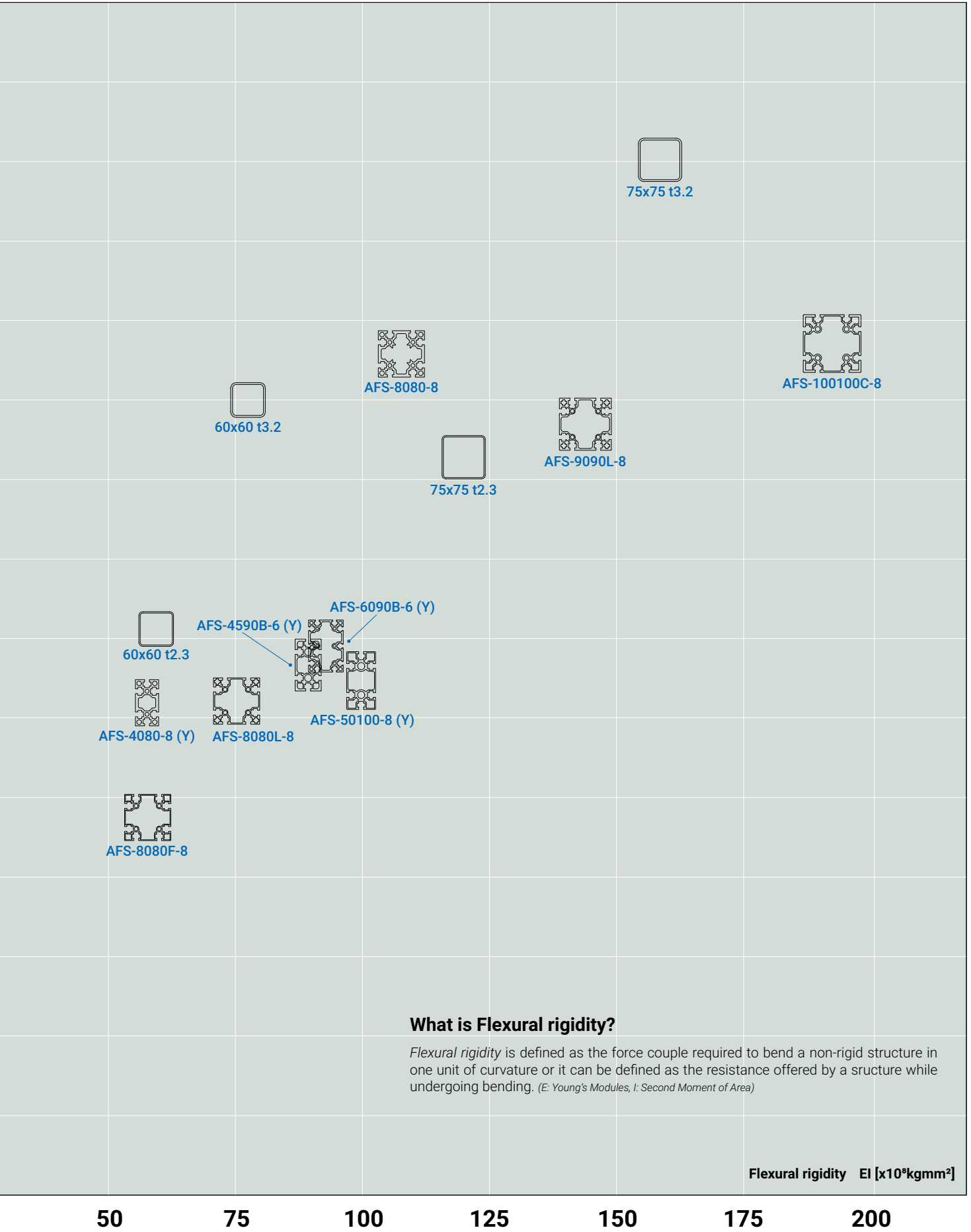

What is Flexural rigidity?

Flexural rigidity is defined as the force couple required to bend a non-rigid structure in one unit of curvature or it can be defined as the resistance offered by a structure while undergoing bending. (E: Young's Modules, I: Second Moment of Area)

Flexural rigidity EI [x10⁹kgmm²]

50 75 100 125 150 175 200



About order code

Aluminium Frame

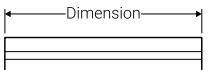
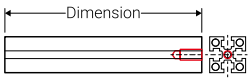
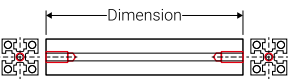
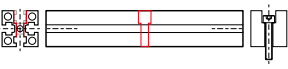
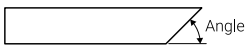
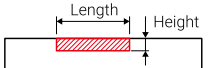
Items manufactured	Order code
Only cutting 	Model Number — Dimension [mm] AFS-2020-4 — 1000
Tapping: One side edge 	Model Number — Dimension [mm] — Tapping AFS-2020-4 — 1000 — T
Tapping: Both side edge 	Model Number — Dimension [mm] — Tapping AFS-2020-4 — 1000 — W
Spot facing 	Order it by a drawing
Angle cutting 	Order it by a drawing
Notched processing 	Order it by a drawing

Tapping Depth M4: Depth 8mm / M6: Depth 12mm / M8: Depth 16mm

Bracket

Items manufactured	Order code
Only bracket	Model Number ABLD-20-4
Tapping	Model Number — Tapping ABLD-20-4 — T

Accessory / Bolt & Nut

Items manufactured	Order code
Accessory	Model Number AHS-4040-4-L-SL
Bolt, Nut, Nut holder	Model Number CS-03-12

Service Information

Global network

TOKYO HEAD OFFICE

Ariake Frontier BLDG. Tower-B 11Fl.,
3-7-26 Ariake, Kohtoh-ku, Tokyou, 135-0063, JAPAN

KITAKANTO BLANCH

309 Moto-abo, Kamikawa-cho, Kodama-gun,
Saitama, 367-0247, JAPAN

TOYAMA HEAD OFFICE / NAGARESUGI PLANT

235, Nagaresugi, Toyama-shi, Toyama, 939-8032, JAPAN

TATEYAMA PLANT / TECHNICAL CENTER

398-176 Tsukagoshi, Tateyama-machi, Naka-Niikawa-gun,
Toyama, 930-0272, JAPAN

TATEYAMA BRANCH

2178-1 Maesawa, Tateyama-machi, Naka-Niikawa-gun,
Toyama, 930-0221, JAPAN

AICHI BRANCH

185 Horogo Narumi-cho, Midori-ku, Nagoya,
Aichi, 458-0801, JAPAN

KANSAI BRANCH

2-4-29 Honjo-nishi, Higashi-osaka-shi,
Osaka, 578-0965, JAPAN

KYUSHU BRANCH

1-2 Shikashin-machi, Omuta-shi, Fukuoka,
837-0907, JAPAN

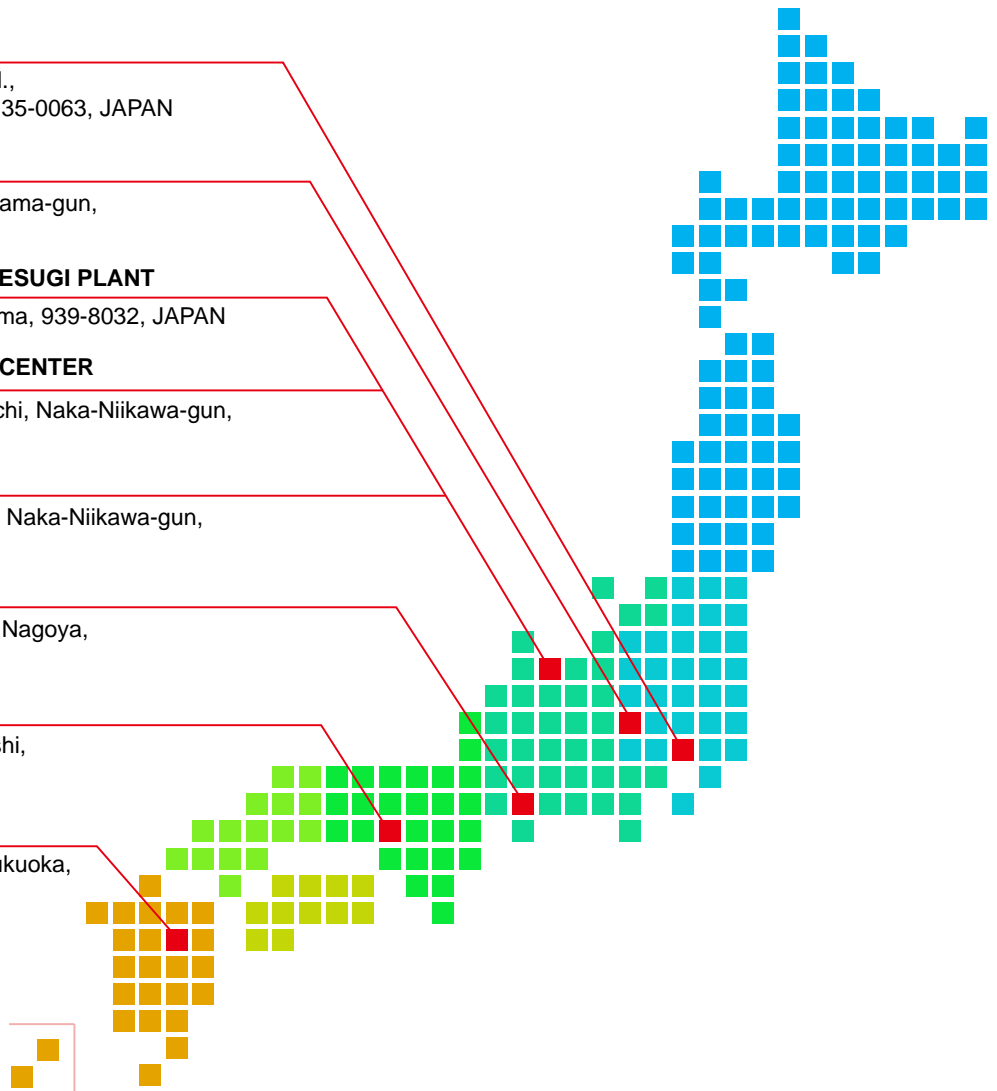

Tokyo head office Tateyama plant / Technical center Toyama head office / Tateyama branch Nagaresugi plant Kansai branch Aichi branch Kyushu branch Kitakanto branch

NIC Autotec (Thailand) Co., Ltd.

นิคม เอเชีย อินดัสเทรียล เอสเตท สุวรรณภูมิ 111/09-10 หมู่ที่ 4
ตำบล คลองสวน อำเภอบางบ่อ จังหวัด สมุทรปราการ 10560
TEL: 02-136-5841~2 FAX: 02-136-5843

Asia Industrial Estate Suvarnabhumi, 111/09-10, Moo.
4, Tambol Klongsuan, Amphur Bangbor, Samutprakarn,
10560 Thailand
TEL: 02-136-5841~2 FAX: 02-136-5843



Memo

←10mm→
←10mm→

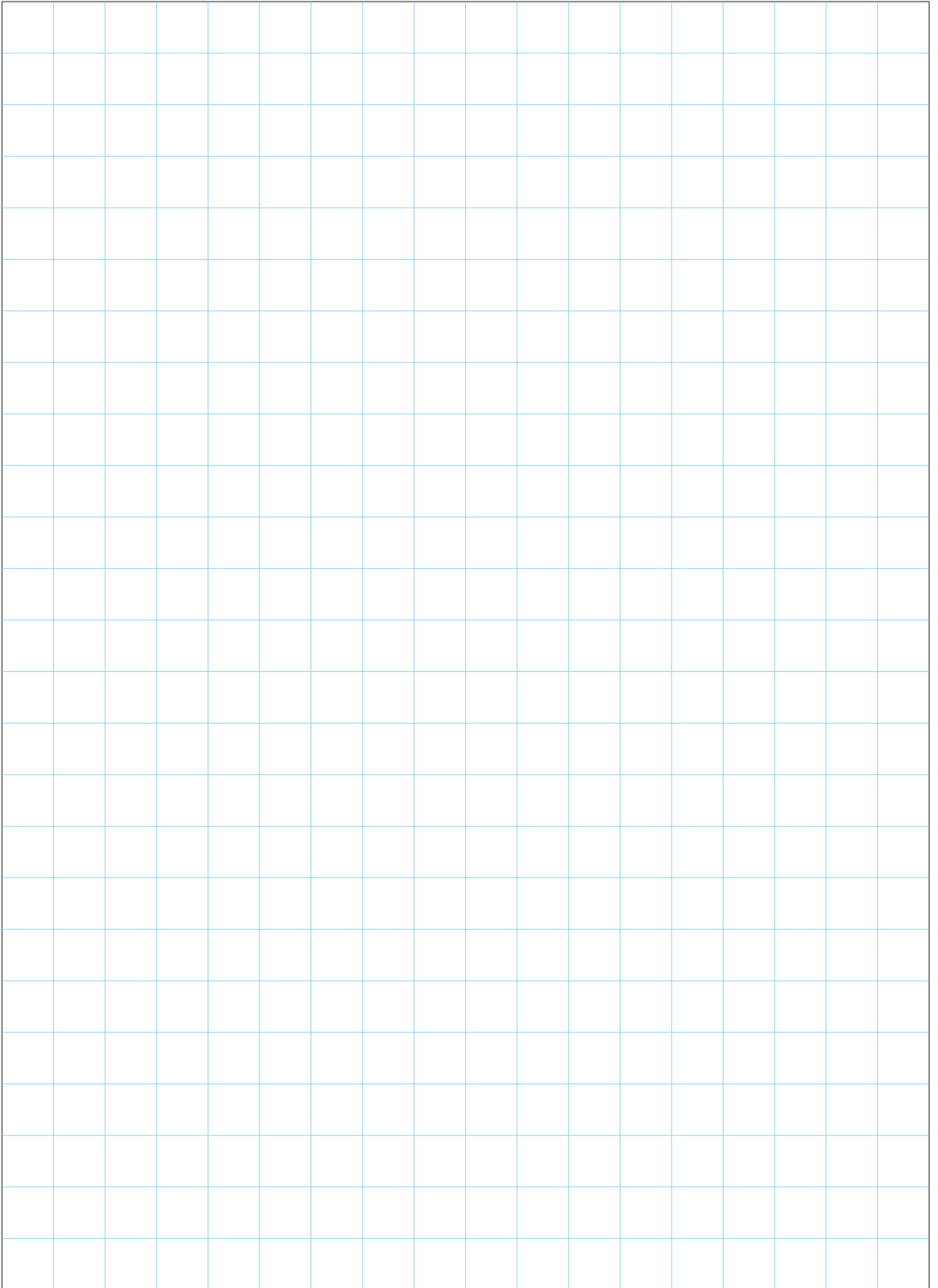

Aluminium Frame

Bracket

Accessory

Bolts & Nuts

Rail Frame

Appendix



ALFA FRAME SYSTEM

บริษัท เอ็นไอซี ออโต้เทค (ประเทศไทย) จำกัด
NIC Autotec (Thailand) Co., Ltd.



Establishment : January 2015

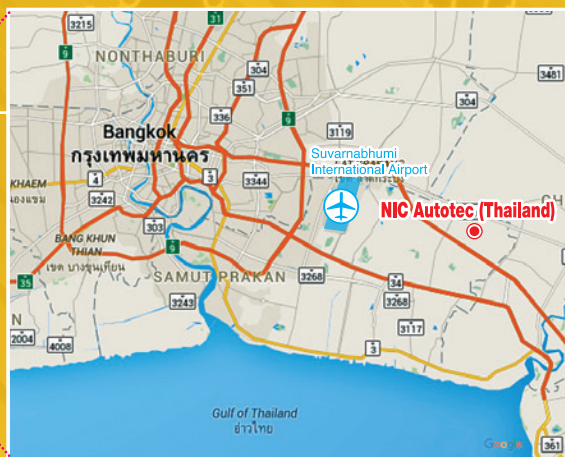

นิคม เอเชีย อินดัสเทรียล เอสเตท สุวรรณภูมิ 111/09-10 หมู่ที่ 4 ตำบล คลองสวน อำเภอบางบ่อ จังหวัด สมุทรปราการ 10560

<https://thai.tech-dir.com/th/companies/186847>

Asia Industrial Estate Suvarnabhumi, 111/09-10, Moo. 4, Tambol Klongsuan, Amphur Bangbor, Samutprakarn, 10560 Thailand

TEL: 02-136-5841~2 FAX: 02-136-5843

<https://thai.tech-dir.com/jp/companies/186847>



Alfa Frame, and Design are registered trademarks of NIC Autotec Corporation in Japan, Thailand and/or other countries.

WARNING: All Rights Reserved. Unauthorized duplication is a violation of applicable laws.

Copyright © NIC Autotec (Thailand) Co., Ltd. All rights reserved.